

MUL-20 Sealless Combination Tool for STEEL Operation Manual

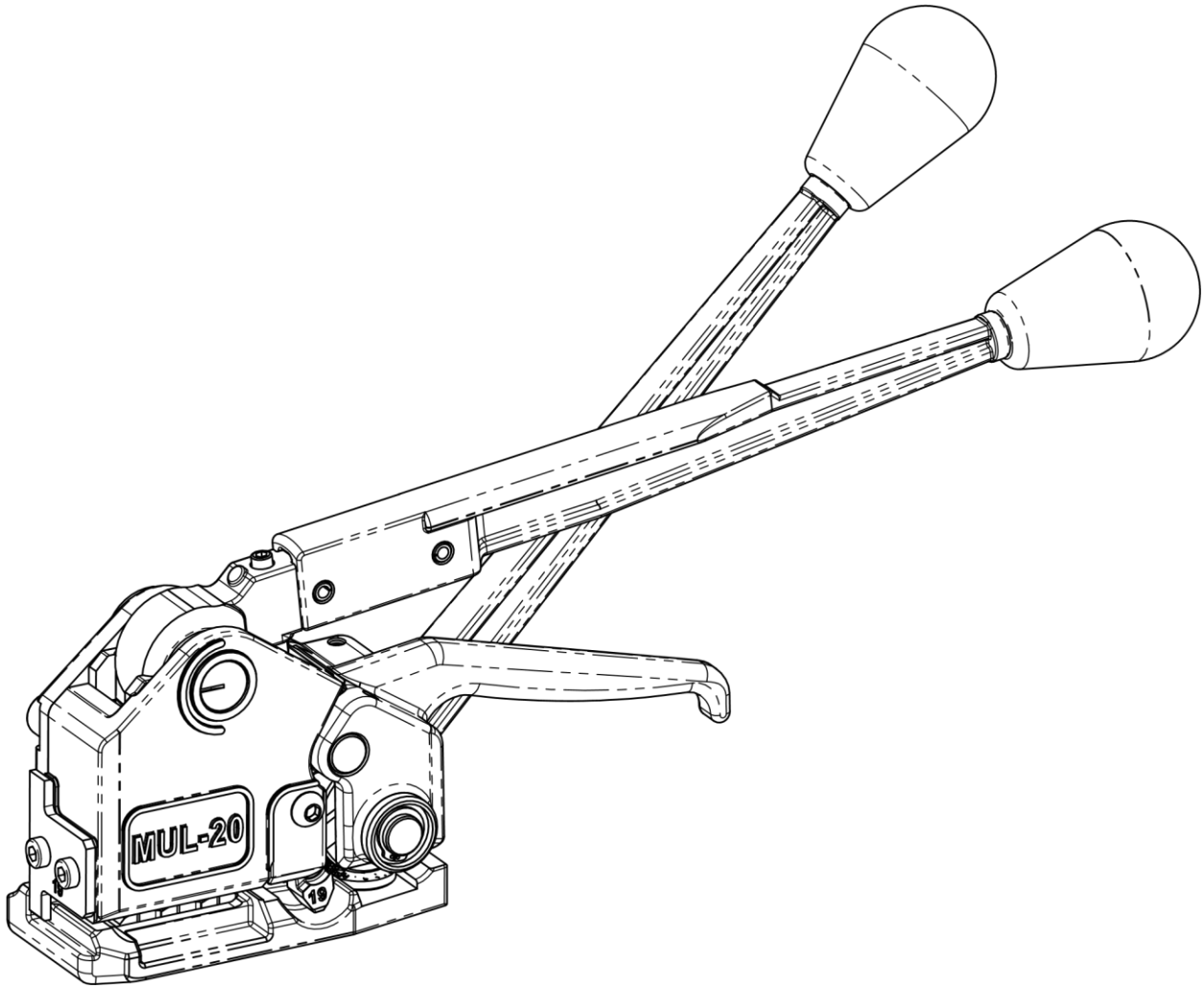

Strap Type	Regular Duty/High Tensile Steel
Strap Width	Adjustable 1/2", 5/8", 3/4" (13, 16, 19 mm)
Strap Thickness	Up to 0.025" (0.64 mm)
Joint Type	Sealless
Weight	9.1 lbs (4.1 kg)
Footprint	L: 4.5"; W: 2.2"

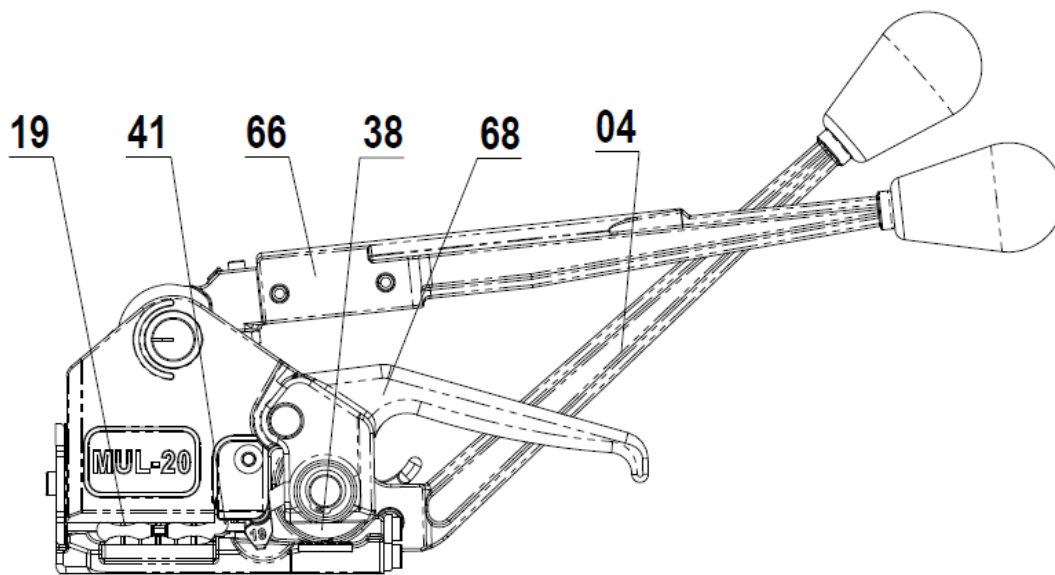

Fig. 1 – Starting Position

1. Pull up on **Feed Wheel Support Handle 68** to raise **Feed Wheel 38**. Load both straps **100** and **101** under **Dies 19**, under **Cutter Blade 41** and under **Feed Wheel 38** and release the **Feed Wheel Support Handle 68** as shown on Fig. 2

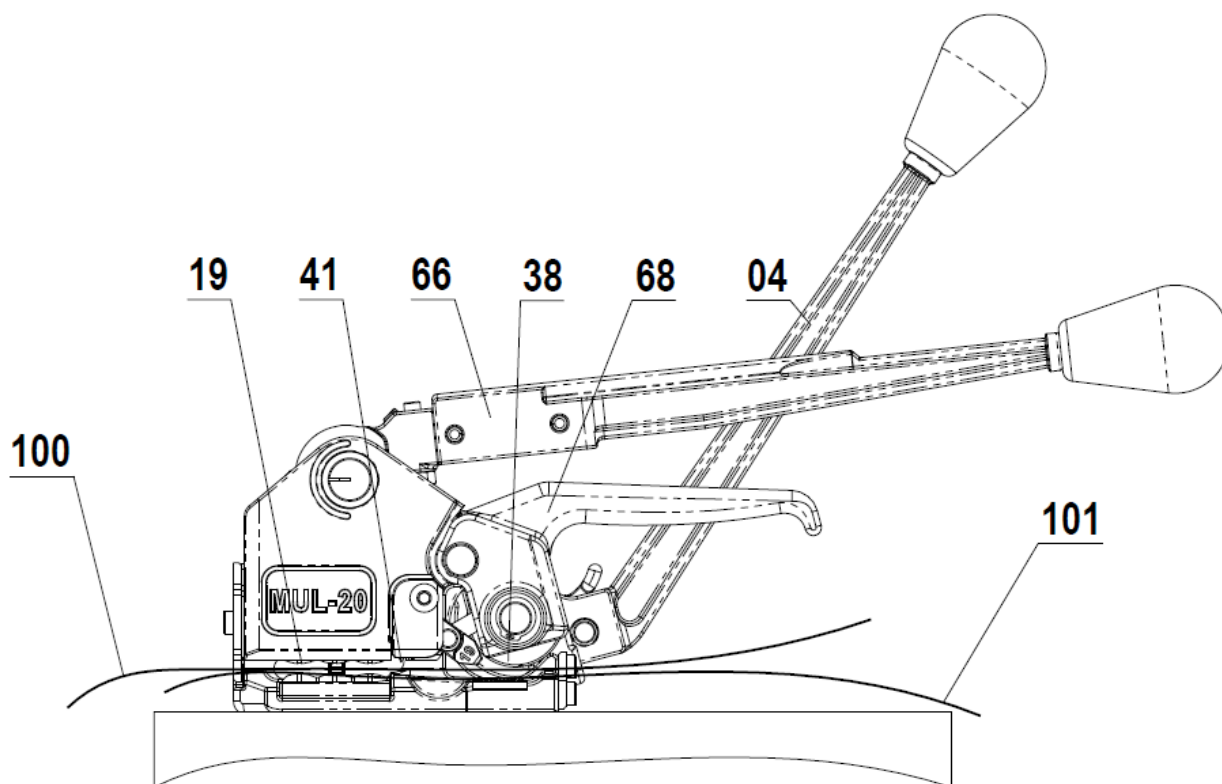

Fig. 2

2. Apply tension by ratcheting **Tension Handle 04** as shown on Fig. 3.

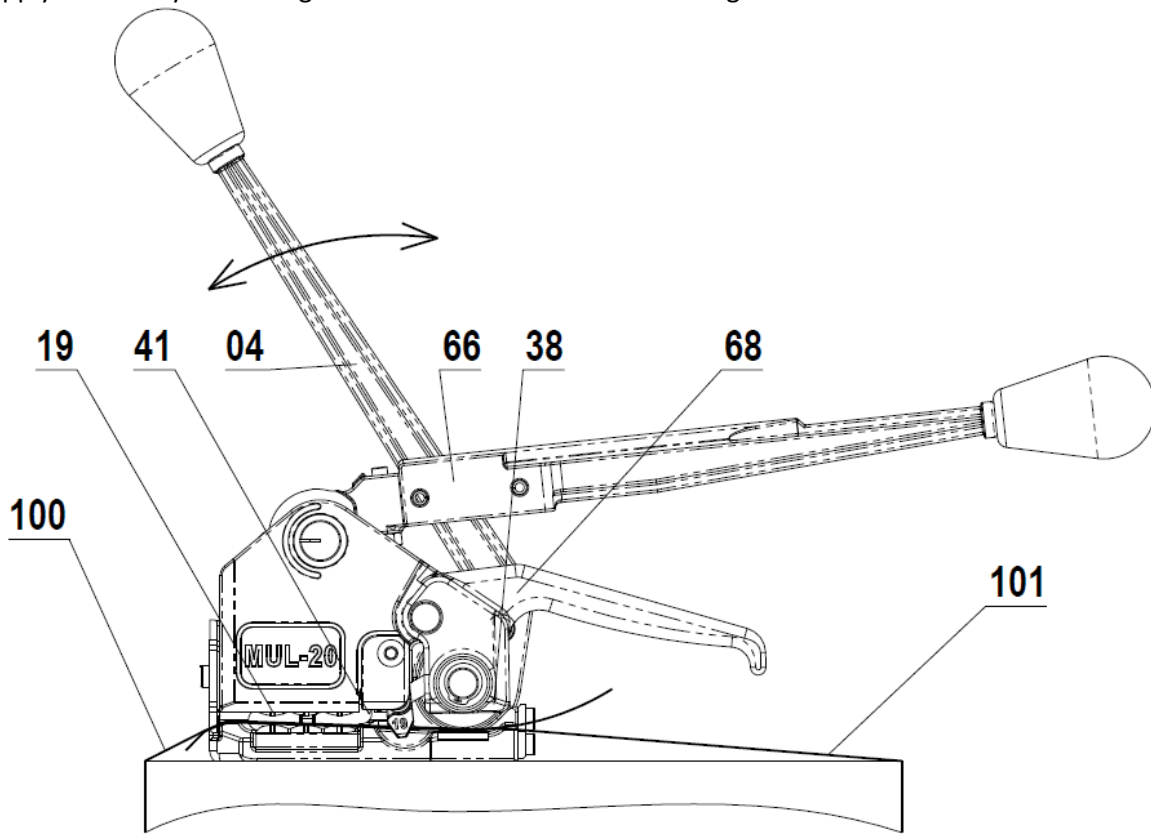

Fig. 3

3. Once satisfactory tension is achieved return **Tension Handle 04** back and push **Sealing Handle 66** forward to seal the joint and cut the excess strap as shown on Fig.4

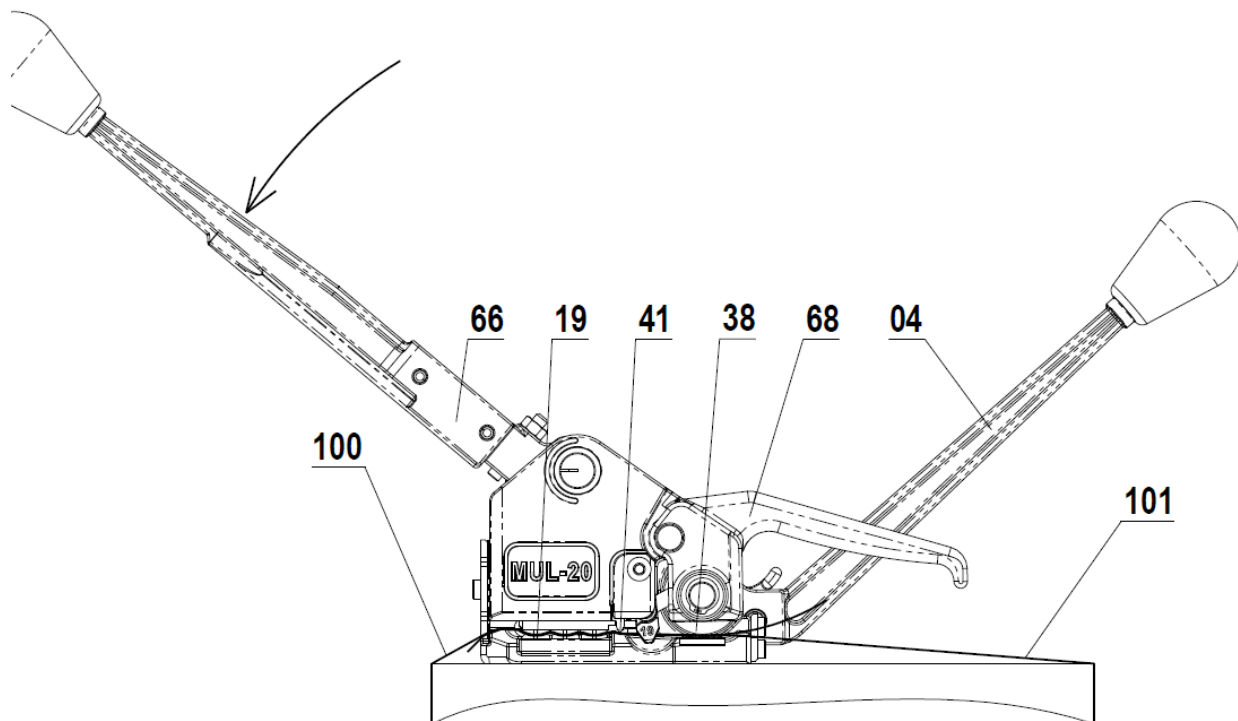

Fig. 4

4. Return **Sealing Handle 66** back and pull up **Feed Wheel Support Handle 68** to release the strap and to remove the tensioner by sliding the backfoot out to the side followed by the front. The operation cycle is now complete.