



Turntable - Mast

EVA
SYNTHESE
SYNTHEX
MYTHO

Use and Maintenance Manual

Translation of the original

Atlanta Stretch S.p.A.

Via Torrianese, 58
47824 - Poggio Torriana - RN
ITALY

Tel. 0541 627145

www.atlantastretch.com

info@atlantastretch.com

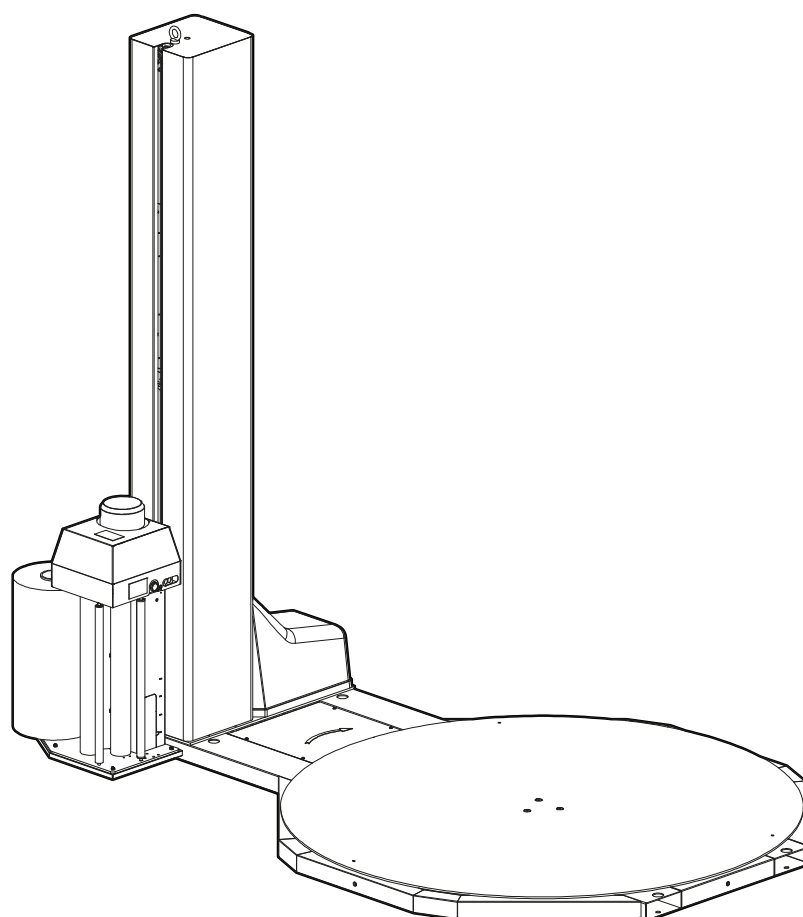

Rev.0 13/01/2020

1	FOREWORD	3
1.1	HOW TO READ AND USE THE INSTRUCTIONS MANUAL.....	3
1.1.1	THE IMPORTANCE OF THE MANUAL.....	3
1.1.2	SAFE KEEPING THE MANUAL.....	3
1.1.3	CONSULTING THE MANUAL.....	3
1.1.4	COPYRIGHT.....	4
1.1.5	INFORMATION ON THE IMAGES AND CONTENTS.....	4
1.1.6	UPDATE OF THE INSTRUCTION MANUAL.....	4
1.1.7	SYMBOLS - MEANING AND USE.....	5
1.2	WHO THE MANUAL IS FOR.....	6
2	SAFETY	7
2.1	GENERAL SAFETY INSTRUCTIONS.....	7
2.2	SAFETY SIGNS.....	8
2.3	WARNINGS OF RESIDUAL RISKS.....	10
2.4	SAFETY DEVICES.....	11
2.4.1	TURNTABLE VERSION WITH TRANSPALLET ACCESS.....	12
2.5	PERSONAL PROTECTIVE EQUIPMENT (PPE).....	13
2.6	TECHNICAL ASSISTANCE.....	13
3	MACHINE DESCRIPTION	14
3.1	MANUFACTURER AND MACHINE IDENTIFICATION DATA.....	14
3.2	GENERAL DESCRIPTION.....	15
3.2.1	OPTIONAL COMBINATIONS AND CARRIAGE.....	22
3.2.2	TABLE OPTIONAL EQUIPMENT.....	23
3.2.2.1	DOOR WINDOW APPLICATION.....	23
3.2.2.2	CARRIAGE GUIDE (roll container).....	26
3.3	ROLL-HOLDER CARRIAGE.....	28
3.3.1	OPTIONAL EQUIPMENT.....	36
3.3.1.1	AUTOMATIC CUT.....	36
3.3.1.2	STRIP CUT.....	37
3.3.1.3	STRIP TIGHTENER (MANUAL VERSION).....	39

3.3.1.4	STRIP TIGHTENER (AUTOMATIC VERSION)	40
3.3.1.5	BUBBLE WRAP	43
3.3.1.6	MESH ROLLER	44
3.3.1.7	FILM WEIGHING	45
3.4	INTENDED USE - PROPER USE - PURPOSE.....	46
3.5	UNINTENDED AND UNAUTHORISED USE - FORESEEABLE AND UNFORESEEABLE IMPROPER USE	49
3.6	TECHNICAL DATA AND NOISE.....	50
3.7	WORK AND CONTROL STATIONS.....	52
4	TRANSPORT-HANDLING-STORAGE	54
4.1	PACKING AND UNPACKING.....	54
4.2	TRANSPORTING AND HANDLING THE PACKED MACHINE	55
4.3	TRANSPORTING AND HANDLING THE UNPACKED MACHINE	56
4.4	STORAGE OF PACKED AND UNPACKED MACHINE.....	58
5	INSTALLATION	60
5.1	PERMITTED AMBIENT CONDITIONS	60
5.2	USE AND MAINTENANCE CLEARANCES	61
5.3	POSITIONING THE MACHINE	62
5.3.1	STANDARD MACHINE.....	62
5.3.2	LOW PROFILE MACHINE	68
5.3.3	TRANSPALLET MACHINE.....	69
5.3.4	MACHINE RECESSED INTO THE FLOOR (WITH FRAME).....	74
5.3.5	MACHINE RECESSED INTO THE FLOOR (WITHOUT FRAME)	75
5.3.6	MACHINE WITH WEIGHING BASE.....	78
5.3.7	MACHINE WITH TRANSPALLET AND WEIGHING BASE	79
5.4	ELECTRICAL CONNECTION	80
6	STARTING UP THE MACHINE	81
6.1	ELECTRICAL PANEL	81

6.2	INSTRUCTIONS FOR USE	82
6.2.1	LOADING A ROLL OF FILM	82
6.2.2	STARTING THE MACHINE.....	82
6.2.3	CYCLE STOP.....	83
6.2.4	STOPPING THE MACHINE AFTER USE	83
6.2.5	EMERGENCY STOP	83
6.2.6	SAFETY SYSTEMS EFFICIENCY CHECK.....	84
6.2.7	EMERGENCY BUTTONS OPERATIONAL CHECK.....	84
7	MAINTENANCE	85
7.1	GENERAL PRECAUTIONS	85
7.1.1	SPECIAL PRECAUTIONS.....	86
7.1.2	CLEANING.....	86
7.2	SCHEDULED MAINTENANCE	86
7.2.1	ACTIVE SAFETY DEVICES MAINTENANCE	87
7.2.2	DAILY MAINTENANCE	88
7.2.3	QUARTERLY MAINTENANCE	88
7.2.4	SIX-MONTHLY MAINTENANCE.....	91
8	OUT OF SERVICE	92
8.1	DISMANTLING, SCRAPPING AND DISPOSAL.....	92
8.2	DISMANTLING ELECTRONIC PARTS (WEEE DIRECTIVE).....	92

IT DICHIARAZIONE 'CE DI CONFORMITA'	RU CE ДЕКЛАРАЦИЯ О СООТВЕТСТВИИ	SE EG-FÖRSÄKRAN OM ÖVERENSSTÄMMELSE
EN EC DECLARATION OF CONFORMITY	HU EK MEGFELELÉSI NYILATKOZAT	NL EG-VERKLARING VAN OVEREENSTEMMING
DE EG-KONFORMITÄTSEKTLÄRUNG	PL DEKLARACJA ZGODNOŚCI WE	CZ ES PROHLÁŠENÍ O SHODĚ CONFORMIDADE
FR DECLARATION DE CONFORMITE CE	DA EF-OVERENSSTEMMELSESEKTLÆRING	FI EY-VAATIMUSTENMUKAISUUSVAKUUTUS
ES DECLARACIÓN DE CONFORMIDAD CE		PT DECLARAÇÃO CE DE CONFORMIDADE

IT IL FABBRICANTE E PERSONA AUTORIZZATA A COSTITUIRE IL FASCICOLO TECNICO:	RU ИЗГОТОВИТЕЛЬ И ЛИЦО, УПОЛНОМОЧЕННОЕ СОСТАВИТЬ ТЕХНИЧЕСКУЮ ДОКУМЕНТАЦИЮ:	SE TILLVERKAREN OCH PERSON SOM ÄR BEHÖRIG ATT SAMMANSTÄLLA DEN TEKNISKA DOKUMENTATIONEN:
EN THE MANUFACTURER AND AUTHORISED PERSON TO COMPILE THE TECHNICAL FILE:	HU A MŰSZAKI DOKUMENTÁCIÓ ÖSSZEÁLLÍTÁSÁVAL MEGBIZOTT SZEMÉLY:	NL DE FABRIKANT EN PERSOON DIE GEAUTORISEERD IS OM HET TECHNISCH DOSSIER OP TE STELLEN:
DE DER HERSTELLER IST DIE ZUR ERSTELLUNG DER TECHNISCHEN UNTERLAGEN BEFUGTE PERSON:	PL PRZYGOTOWANIA DOKUMENTACJI TECHNICZNEJ:	CZ VÝROBCE A OSOBA OPRAVNĚNÁ K SEŠTAVENÍ TECHNICKÉHO SOUBORU:
FR LE FABRICANT ET LA PERSONNE AUTORISÉE À CONSTITUER LE DOSSIER TECHNIQUE:	DK PRODUCENTEN ER AUTORISERET TIL AT UDFØRE DEN TEKNISKE DOKUMENTATION:	FI VALMISTAJA JA TEKNISEN TIEDOTTEEN LAADINTAAN VALTUUTETTU HENKILÖ:
ES EL FABRICANTE Y LA PERSONA AUTORIZADA PARA ELABORAR EL INFORME TÉCNICO:		PT O FABRICANTE E PESSOA AUTORIZADA A CONSTITUIR FASCÍCULO TÉCNICO:

ATLANTA STRETCH Spa, via Torrianese, 58 - 47824 POGGIO TORRIANA (RN) - ITALY

IT DICHIARA SOTTO LA PROPRIA RESPONSABILITÀ CHE LA MACCHINA IDENTIFICATA	RU ЗАВЯЛЯЕТ, ЧТО ОБМОТЧИК СООТВЕТСТВУЕТ ТРЕБОВАНИЯМ	SE FÖRSÄKRAR HÄRMED ATT MASKINEN MED FÖLJANDE EGENSKAPER
EN DECLARES ON HIS OWN RESPONSIBILITY THAT THE MACHINE IDENTIFIED AS FOLLOW	HU SAJÁT FELELŐSÉGÉRE KIJELENTI, HOGY AZ ALÁBBI AK SZERINT AZONOSÍTOTT	NL VERKLAART VOOR EIGEN VERANTWOORDELIJKHEID, DAT DE GEÏDENTIFICEERDE MACHINE
DE ERKLÄRT UNTER EIGENER VERANTWORTUNG DASS DIE IDENTIFIZIERTE MASCHINE	PL OŚWIADCZA NA WŁASNA ODPOWIEDZIALNOŚĆ IŻ OZNACZONA MASZYNA GEP	CZ PROHLÁŠUJI NA SVOU ZODPOVĚDNOST ŽE STROJ S NÁSLEDUJÍCÍM OZNAČENÍM
FR DECLARE SOUS SA RESPONSABILITE QUE LA MACHINE IDENTIFIEE	DK ERKLÆRER PÅ EGET ANSVAR, AT MASKINEN IDENTIFICERET SOM	FI VAKUUTETA OMA LLA VASTUULLAAN, ETTÄ ILMOITETTU LAITE
ES DECLARA BAJO SU RESPONSABILIDAD QUE LA MÁQUINA IDENTIFICADA		PT DECLARA SOB SUA PRÓPRIA RESPONSABILIDADE QUE A MÁQUINA IDENTIFICADA

IT TIPO: AVVOLGITORE	RU ТИП: ОБМОТЧИК	SE TYP: STRÄCKFILMSMASKIN
EN TYPE: WRAPPING MACHINE	HU TÍPUS: TEKERCELŐ	NL TYPE: BANDEROLEUSE
DE TYP: WICKELMASCHINE	PL TYP: OWIJARKA	CZ TYP: BALÍČÍ STROJ
FR TYPE: BANDEROLEUSE	DK TYPE: VIKLEMASKINE	FI TYYPPI: LAVAKÄÄRINTÄLAITE
ES TIPO: ENFARDADORA		PT TYPE: ENVOLVEDOR

IT MODELLO	RU МОДЕЛЬ	SE MODELL
EN MODEL	HU MODELL	NL MODEL
DE MODELL	PL MODEL	CZ MODEL
FR MODÈLE	DK MODEL	FI MALLI
ES MODELO		PT MODELO

--	--	--

IT MATRICOLA	RU СЕРИЙНЫЙ НОМЕР	SE SERIENUMMER
EN SERIAL NUMBER	HU SOROZATSÁMA	NL SERIENUMMER
DE SERIENUMMER	PL NUMER FABRYCZNY	CZ SÉRIOVÉ ČÍSLO
FR NUMÉRO DE SÉRIE	DK SERIENUMMER	FI SARJANUMERO
ES N° SERIE		PT N° DE SÉRIE

--	--	--

IT E' CONFORME ALLE DIRETTIVE COMUNITARIE	RU СООТВЕТСТВУЕТ ДИРЕКТИВАМ ЕВРОПЕЙСКОГО СООБЩЕСТВА	SE ÄR TILLVERKAD I ÖVERENSSTÄMMEISE MED GÄLLANDE EU-DIREKTIV
EN IN CONFORMITY WITH THE FOLLOWING DIRECTIVES	HU MEGFELEL A VONATKOZÓ EURÓPAI IRÁNYELVEKNEK	NL CONFORM IS MET COMMUNAUTAIRE RICHTLIJNEN INZAKE
DE IS DEN FOLGENDEN EU-RICHTLINIEN ENTSPRICHT	PL JEST ZGODNA Z ODPOWIEDNIMI DYREKTYWAMI WSPÓLNOTOWYMI	CZ JE V SOULADU S NÁSLEDUJÍCÍ SMĚRNICÍ
FR EST CONFORME AUX DIRECTIVES COMMUNAUTAIRES RELATIVES AUX/A	DK ER UDARBEJDET I ÖVERENSSTÄMMEISE MED DE GÄLDENDE EU-DIREKTIVER	FI ON SEURAAVIEN YHTEISÖN DIREKTIVIEN MUKAINEN
ES ES CONFORME A LAS DIRECTIVAS COMUNITARIAS SOBRE		PT ESTÁ EM CONFORMIDADE COM AS DIRETIVASOMUNITARIAS

2006/42/CE & 2014/30/UE

IT E NORME	RU И НОРМЫ	SE OCH STANDARDER
EN AND STANDARDS	HU ÉS NORMÁK	NL EN NORMEN
DE UND NORMEN	PL I NORMY	CZ A NORMY
FR ET NORMES	DK OG STANDARDER	FI JA MÄÄRÄYKSET
ES Y NORMAS		PT E NORMAS

EN ISO 12100:2010 & EN 60204-1:2006

IT DICHIARAZIONE ORIGINALE IN LINGUA ITALIANA.	RU ПЕРЕВОД ОРИГИНАЛА ДЕКЛАРАЦИИ НА ИТАЛЬЯНСКОМ ЯЗЫКЕ.	SE ÖVERSÄTTNING ORIGINALDEKLARATION PÅ ITALIENSKA.
EN TRANSLATION OF ORIGINAL DECLARATION IN ITALIAN.	HU FORDÍTÁS AZ EREDETI NYILATKOZAT OLASZ NYELVŰ.	NL VERTALING VAN DE ORIGINELE VERKLARING IN HET ITALIAANS.
DE ÜBERSETZUNG DER ORIGINALERKLÄRUNG AUF ITALIENISCH.	PL TRANSLACJA ORYGINALNE OŚWIADCZENIE W JEZYKU WŁOSKIM.	CZ PŘEKLAD ORIGINÁLNÍ PROHLÁŠENÍ V ITALSKÉM JAZYKU.
FR TRADUCTION DES DÉCLARATION ORIGINALE EN LANGUE ITALIENNE.	DK OVERSÆTTELSE ORIGINAL ERKLÆRING PÅ ITALIENSK.	FI KÄÄNNÖS ALKUPERÄINEN ILMOITUS.
ES TRADUCCIÓN DE DECLARACIÓN ORIGINAL EN ALIANO.		PT TRADUÇÃO DECLARAÇÃO ORIGINAL EM ITALIANO.

IT LUOGO E DATA:	RU МЕСТО И ДАТА:	SE ORT OCH DATUM:
EN PLACE AND DATE:	HU KÉLT:	NL PLAATS EN DATUM:
DE ORT UND DATUM:	PL MIEJSCE I DATA:	CZ MÍSTO A DATUM:
FR LIEU ET DATE :	DK DATO OG STED:	FI PAIKKA JA PÄIVÄYS:
ES LUGAR Y FECHA:		PT LOCAL E DATA:

Poggio Torriana

IT IL LEGALE RAPPRESENTANTE (ANGELO FORNI)	RU ЮРИДИЧЕСКИЙ ПРЕДСТАВИТЕЛЬ (ANGELO FORNI)	SE JURIDISKT OMBUD (ANGELO FORNI)
EN LEGAL REPRESENTATIVE (ANGELO FORNI)	HU A TÖRVÉNYES KÉPVISELŐ (ANGELO FORNI)	NL DE WETTELIJKE VERTEGENWOORDIGER(ANGELO FORNI)
DE GESETZLICHER VERTRETER (ANGELO FORNI)	PL PRZEDSTAWICIEL USTAWOWY (ANGELO FORNI)	CZ PŘÁVNÍ ZÁSTUPCE (ANGELO FORNI)
FR LE REPRÉSENTANT LÉGAL (ANGELO FORNI)	DK DEN ADMINISTRERENDE DIREKTØR (ANGELO FORNI)	FI LAILLINEN EDUSTAJA (ANGELO FORNI)
ES EL REPRESENTANTE LEGAL (ANGELO FORNI)		PT O REPRESENTANTE LEGAL (ANGELO FORNI)

ATLANTA STRETCH S.p.a.

1 FOREWORD

1.1 HOW TO READ AND USE THE INSTRUCTIONS MANUAL

1.1.1 THE IMPORTANCE OF THE MANUAL

The instruction manual is to be considered as an integral part of the product; keep it and look after it throughout the lifetime of the machine and hand it on to any other users or subsequent owners.

All the instructions contained in the manual must be followed by both operators and qualified staff in order to correctly and safely install, start, use and service the machine.

In the event of doubts or problems, contact the technical service centres.

1.1.2 SAFE KEEPING THE MANUAL

Use the manual in such a way as not to damage all or part of the contents.

On no account should any parts of this manual be removed, torn out or rewritten.

Keep the manual in places protected from humidity and heat.

Keep this manual and all the related publications in an accessible place known to all the operators.

All use and maintenance operations concerning commercial machine components that are not indicated in this manual are contained in the relative publications attached to it.

1.1.3 CONSULTING THE MANUAL

This instruction manual is made up of:

- COVER WITH MACHINE IDENTIFICATION
- INSTALLATION AND ASSEMBLAGE
- INSTRUCTIONS AND/OR NOTES ON SAFETY USE OF THE PRODUCT
- ATTACHMENTS

1.1.4 COPYRIGHT

This manual contains confidential industrial information belonging to MANUFACTURER.

All rights are reserved and may be protected by copyright or other ownership laws and treaties.

No part of this manual may be reproduced in any form or by any means without explicit permission from MANUFACTURER.

1.1.5 INFORMATION ON THE IMAGES AND CONTENTS

The illustrations in this manual have been included solely by way of example for better understanding of what is described.

This document may be subject to change by Manufacturer without prior notice, but the information on safe use is still guaranteed.

1.1.6 UPDATE OF THE INSTRUCTION MANUAL

The essential features of the type of machine described being understood, Manufacturer reserves the right to make any modifications to the devices, details and accessories as it sees fit for product improvement or for construction or commercial requirements.

1.1.7 SYMBOLS – MEANING AND USE

Typographic messages and symbols are used in this manual to refer to particular procedures which, if not observed, could cause damage to people, animals, things and the environment.

DANGER



*Indicates a hazard with the risk of mortal injury.
Failure to observe warnings marked by this symbol can lead to a situation of serious risk to the safety of the operator and/or exposed persons.*

WARNING



*Indicates a hazard with the risk of danger to the machine or the product being processed.
Failure to observe warnings marked by this symbol can lead to malfunction or damage to the machine.*

INFORMATION



Indicates notes and advice for practical machine use in the different operating modes.

1.2 WHO THE MANUAL IS FOR



MACHINE OPERATOR:

Operator who, after an appropriate training course in the use of the machine, is able to make the simplest adjustments.



MECHANICAL MAINTENANCE TECHNICIAN:

Qualified technician able to operate the machine like the machine operator and work on the mechanical devices for adjustment, maintenance and repair. The mechanical maintenance technician is not qualified to perform operations on live electrical systems.



MAINTENANCE ELECTRICIAN:

Qualified technician able to operate the machine like the machine operator, make adjustments and work on electrical systems for maintenance and repair.



SPECIALISED TECHNICIAN OF THE MANUFACTURER:

Qualified technician of the manufacturer or his distributor able to operate the machine like the machine operator, work on the mechanical devices and on the electrical system for adjustments, maintenance, repairs and complex operations when agreed with the user.



EXPOSED PERSON:

Any person partially or fully in a hazardous zone.

2 SAFETY

2.1 GENERAL SAFETY INSTRUCTIONS

Before starting work, the operator must be perfectly familiar with the position and functioning of all the controls and machine features. Daily check all the safety devices on the machine.

- Before starting the working cycle, the operator must ensure that there are no EXPOSED PERSONS in the HAZARDOUS ZONES.
- The employer must provide and instigate the use of personal protective equipment conforming to the prescriptions of Directive 89/391/EEC (and subsequent revisions). While using and carrying out maintenance on the machine the use of personal protective equipment (PPE) such as safety footwear and overalls, approved for accident prevention, is obligatory.
- The areas where the operator stands must always be kept clear and free of oily residues.
- It is forbidden to approach the moving parts of the machine, such as the carriage and rotating parts, when the machine is in operation.
- It is strictly prohibited to operate the machine in automatic mode with the fixed and/or mobile safety guards removed.
- It is strictly prohibited to disable the safety devices installed on the machine.
- Any adjustment operations that need to be carried out with some of the safety devices disabled must be performed by one person only, and unauthorised persons may not access the machine during this time.
- The room in which the machine is housed must not have any shadow areas, annoying bright lights or hazardous stroboscopic effects caused by the lighting supplied.
- The machine can operate in clear air conditions at ambient temperatures of +5°C to +40°C.
- The machine must be used exclusively by qualified personnel.

DANGER



THE MACHINE MUST ONLY BE USED BY ONE OPERATOR AT A TIME, USE OF THE MACHINE BY 2 OR MORE OPERATORS AT THE SAME TIME IS FORBIDDEN.

DANGER



During all maintenance, repair or adjustment operations, IT IS OBLIGATORY TO TURN THE MAIN SWITCH TO (0-OFF).

If you need to conduct work inside the electrical panel, always turn off the voltage upstream the machine using the mains switch, as the terminal board is powered on even though the panel is open and the machine switch is set to "OFF".

It is advisable to post a warning sign on the control panel onboard the machine or on the main power switch (whatever applicable); this sign should read as follows:

WARNING! DO NOT TOUCH - MAINTENANCE STAFF AT WORK.

DANGER



DO NOT REMOVE THE FIXED GUARDS WHEN THE MACHINE IS RUNNING. ALWAYS REFIT THE FIXED GUARDS AFTER ANY MAINTENANCE OPERATION.

DANGER



IT IS PROHIBITED TO ATTEMPT TO COUNTERACT, SLOW DOWN OR STOP THE MACHINE DURING THE AUTOMATIC WRAPPING CYCLE. USE ONLY THE STOP BUTTON OR THE EMERGENCY BUTTON TO BRING IT TO A HALT.

As soon as possible after an operation that required disabling of some safety devices, the machine must be restored to a safe state by re-enabling all the safety devices.

Do not for any reason modify parts of the machine (e.g. attachments, holes, finishes, etc.) in order to adapt it to other devices. We therefore advise you to request any modifications directly from the Manufacturer.

2.2 SAFETY SIGNS

The safety signs described in this manual, are located on the machine structure at suitable points and warn of the likelihood of danger due to residual risks.

The adhesive stickers, distinguished by yellow and black bands, warn of areas of risk for operators and so maximum care must be taken where these signs are located.

The adhesive stickers applied to the machine must always be kept clean and legible.

» See Picture 1 - pag. 9



- High voltage hazard.



- Cut off power to the machine before opening the electrical panel.



- It is forbidden to remove fixed safety guards.



- It is forbidden to transit or remain in areas with moving parts.



- It is obligatory to read the instruction manual carefully before operating the machine.



- Pick-up point for lifting and handling with a fork lift truck.



- It is obligatory to switch off the machine and remove the plug before starting any maintenance operations or repairs.



- Danger of falling from the turntable.



- Finger crushing hazard due to moving parts.

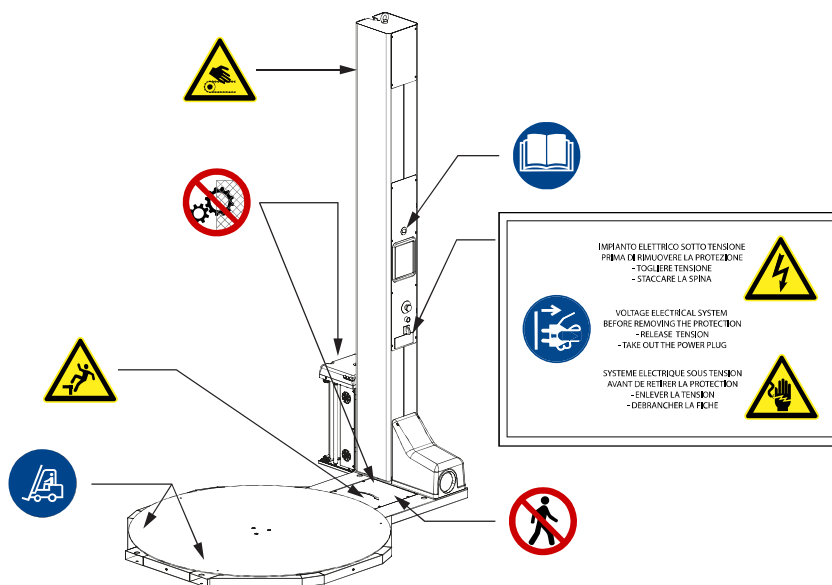

Picture 1

2.3 WARNINGS OF RESIDUAL RISKS

» See Picture 2 - pag. 10

The machine has been designed and constructed in such a way as to allow the operator to use it safely, eliminating or cutting down to the minimum the possible residual risks by the adoption of safety devices. It has not been possible however to eliminate some risks, listed below, because these are inherent in the way the machine works.

DANGER



Risk of getting trapped
Never climb onto the turntable (1) while it is moving as you may fall or get caught up in the film winding zone.

DANGER



Risk of getting crushed
Do not stand in the area of rotation of the turntable with transpallet compartment as there is a risk of getting crushed. The operator would risk getting a foot caught between the turntable and the base at point (2).

DANGER



Risk of getting crushed
Do not remain in or pass through the carriage movement area. In the lowering phase there is the risk of impact and being crushed between the carriage safety plate (3) and the ground.

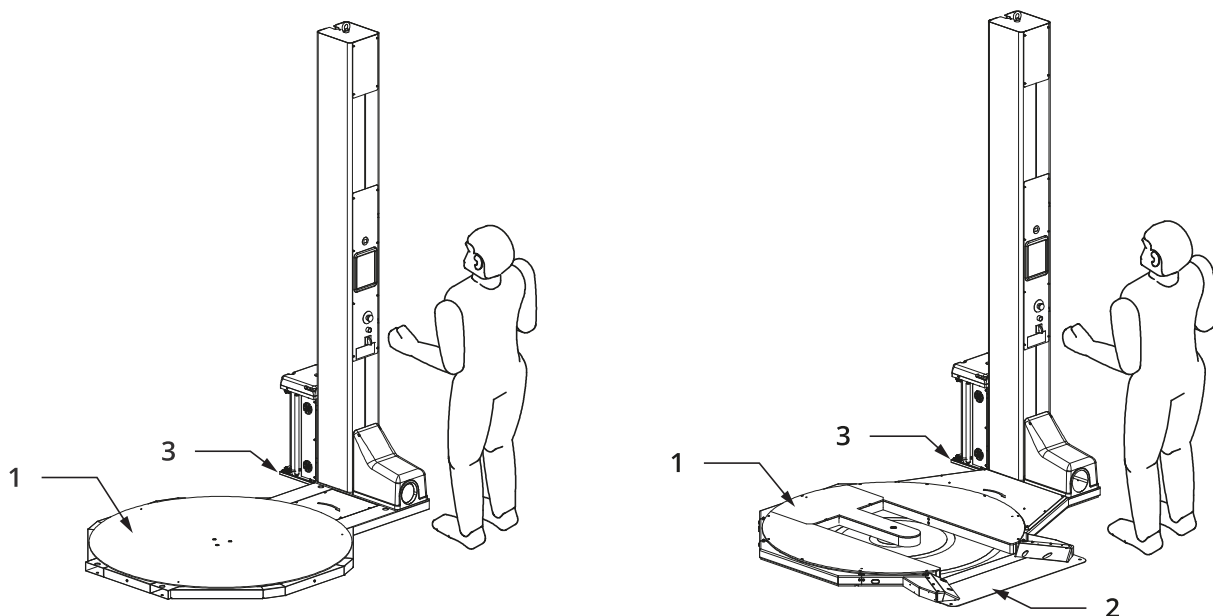

Picture 2

2.4 SAFETY DEVICES

DANGER



The machine has been designed and constructed to allow safe use in all the conditions intended by the manufacturer, isolating the moving parts and live components by the use of SAFETY GUARDS and SAFETY devices to stop the machine.

The manufacturer declines all responsibility for damage or injury to persons, animals or objects caused by tampering with the safety devices.

» See Picture 3 - pag. 11

- Emergency button **(A)** on the electrical panel.
- The top area of the carriage, where the drive transmission gears are, is protected by fixed guard **(B)**.
- The moving parts of the turntable are protected by fixed guard **(C)**.
- The electrical panel is protected by fixed guard **(D)**.
- Under the carriage there is a mobile plate **(E)** interlocked by a safety switch which, if the plate comes into contact with a foreign object it stops the machine and sends the carriage back up for 2 seconds.

N.B: if the machine stops because devices **(E)** has been triggered, the carriage can be sent up to remove the foreign object that triggered it.

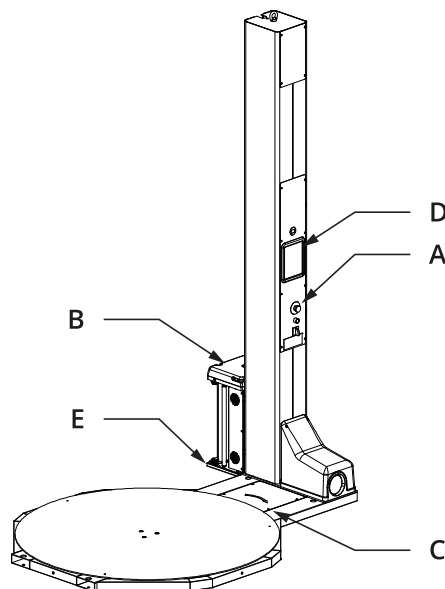

Picture 3

2.4.1 TURNTABLE VERSION WITH TRANSPALLET ACCESS

» See Picture 4 - pag. 12

A photocell (**G**) is located at the entrance to the transpallet access. If this is obscured it prevents the machine from starting or stops it immediately if it is working.

DANGER



CHECK THE SAFETY PHOTOCELL BEFORE STARTING WORK.

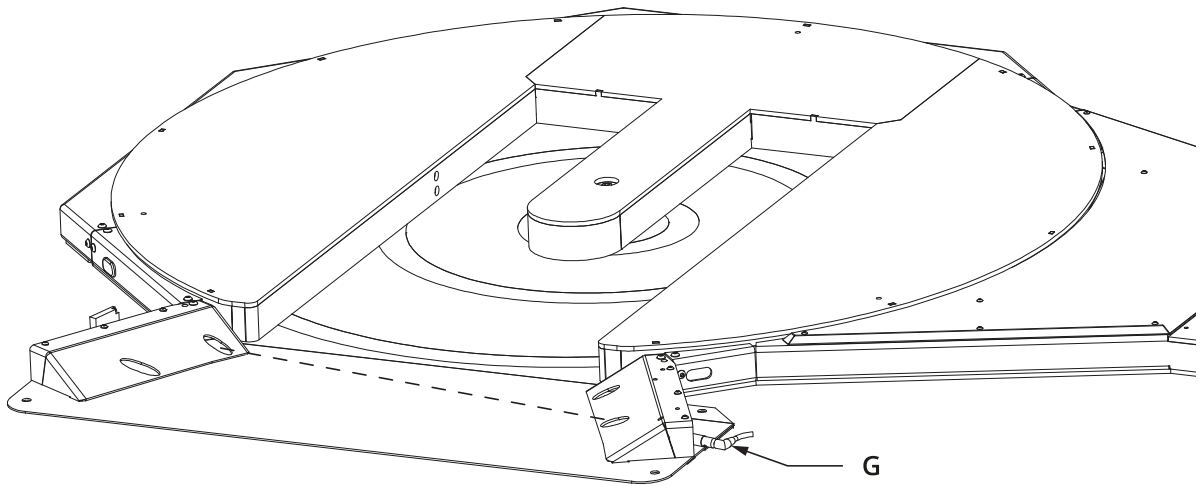

Picture 4

2.5 PERSONAL PROTECTIVE EQUIPMENT (PPE)

The following personal protective devices are necessary for handling, installation, use, maintenance, and dismantling.



- Compulsory use of gloves.



- Safety shoes required.



- Protective clothing required.



- Compulsory use of helmet.
-

2.6 TECHNICAL ASSISTANCE

For any orders, assistance or information, the user should contact the Manufacturer quoting the following details:

- Machine model
- Serial number
- Year of manufacture
- Purchase date
- Approximate number of service hours
- Detailed indications regarding a specific operation to be carried out or the fault found.

TECHNICAL ASSISTANCE

see COVER WITH MACHINE IDENTIFICATION

Best performance of our machines can only be maintained and guaranteed if original spare parts are used.

3 MACHINE DESCRIPTION

3.1 MANUFACTURER AND MACHINE IDENTIFICATION DATA

see COVER WITH MACHINE IDENTIFICATION

The Identification plate, fixed to the machine chassis, shows the following information:

- Manufacturer's name and address
- Machine type
- Machine model
- Serial number
- Year of manufacture
- Weight (kg)
- Nominal voltage (Un)
- Operating frequency (Hz)
- No. of phases
- Nominal current (In)
- Short circuit current (Icc)
- Air pressure (bar)
- Air consumption (NI/cycle).

» See Picture 5 - pag. 14

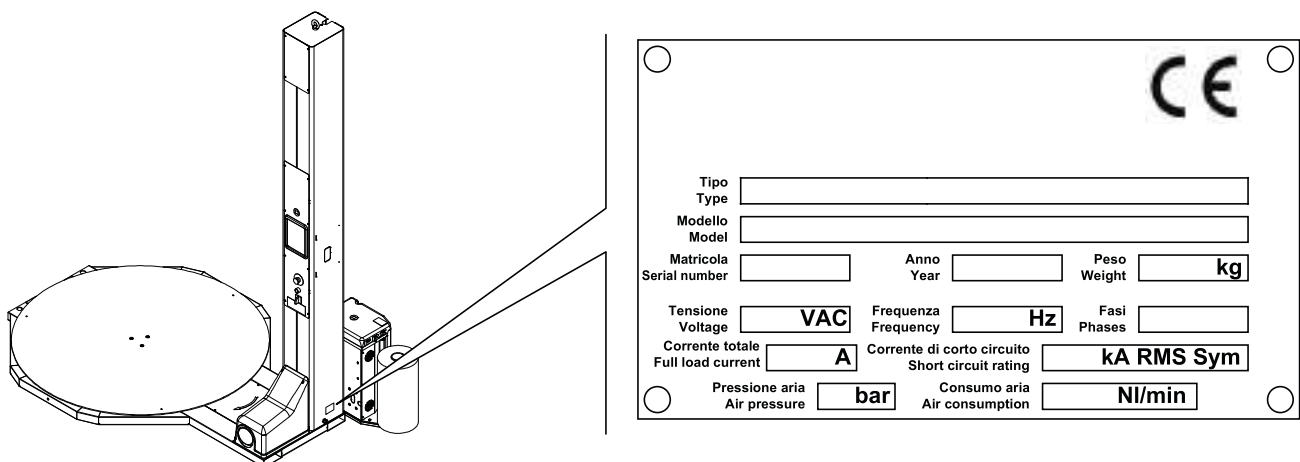

Picture 5

3.2 GENERAL DESCRIPTION

The wrapping machine is a semiautomatic designed to wrap and stabilize palletizable products by means of a stretch film. The **standard** machine is comprised of the following parts:

» See Picture 6 - pag. 15

- 1) **Turntable:** table on which the palletised product to be wrapped is placed.
- 2) **Column** along which a wrapping tool.
- 3) **Roll holder carriage** that moves vertically up and down; the vertical movement of the roll holder carriage, combined with the rotation of the table, wraps the product.
- 4) **Electric panel**, structure containing the main switch, the control pushbutton panel and the electrical components.

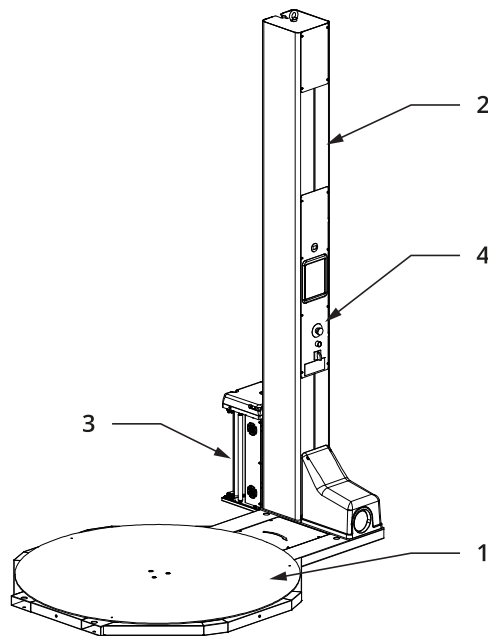

Picture 6

The **standard** machine must work in specific environmental conditions, as indicated in the par. "5.1 PERMITTED AMBIENT CONDITIONS" pag. 60.

For operation in special environmental conditions, the machine may be built with certain features:

Freezer

Machines built with special features for use in environments with low temperatures such as cold rooms (down to -30 ° C).

Stainless Steel

Machines built with special features for use in:

- oxidizing environments, i.e., those with high humidity or when the work areas and the machine itself will be washed;
- corrosive environments, e.g., those with a highly saline atmosphere.

Depending upon the model chosen, the machine may be equipped with one of the following for wrapping carriages: FM - FE - 1PRS/PRS and PS (MB-EB-EMPS/MPS-MPS2).

FM (MB) carriage: delivers film during winding and adjusts its application tension. Tension is governed by a roller fitted with a mechanical brake which can be manually adjusted with a knob located on the carriage.

FE (EB) carriage: delivers film during winding and adjusts its application tension. Tension is governed by a roller fitted with an electromagnetic brake which can be manually adjusted with a knob located on the carriage.

1PRS/PRS (EMPS/MPS) carriage: delivers film during winding and adjusts its application tension to the load. The carriage can pre-stretch the film by means of a mechanical control generated by a pair of gears (fixed mechanical ratio). Application tension is manually.

PS (MPS2) carriage: delivers film during winding and adjusts its application tension to the load. The carriage can pre-stretch the film at a variable ratio which is set from the operator's panel. Application tension is manually. Adjusted and controlled by a sensor which measures its value.

For specific information on the carriages, see par. "3.3 ROLL-HOLDER CARRIAGE" pag. 28.

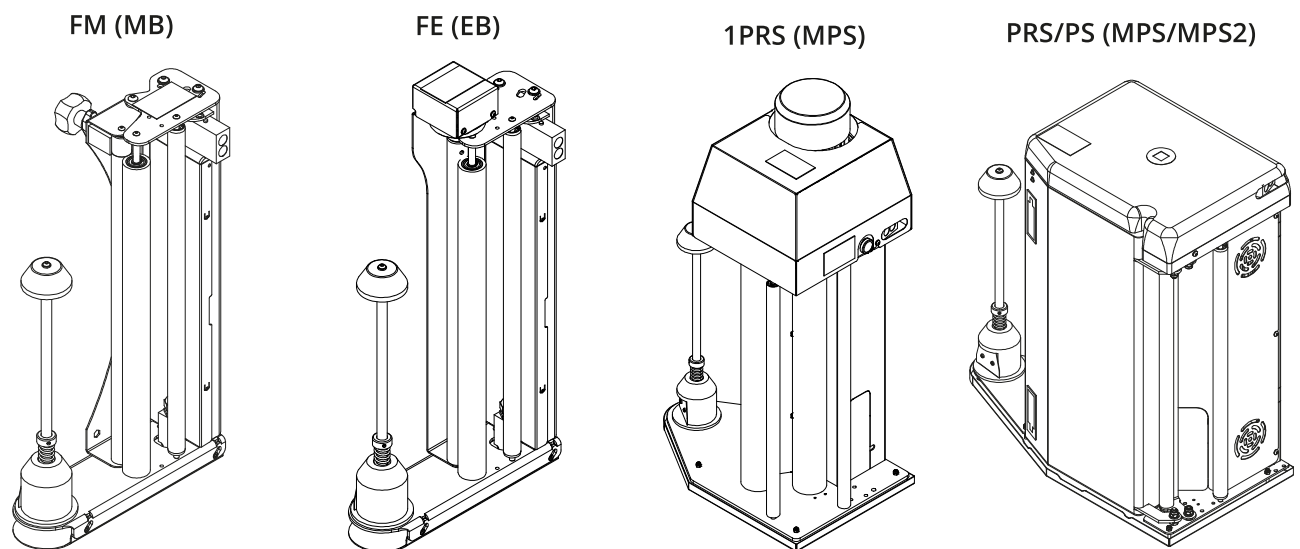

Picture 7 - Wrapping carriages available

The machine may be supplied on request in the following versions:

» See Picture 8 - pag. 18

- Open base with low ramp (**A**) to allow a forklift truck (manual or electric transpallet) to enter and place pallets directly onto the turntable
- Recessed (**B**) for facilitating loading and unloading the pallets as the turntable lies flush with the floor. The customer must prepare a suitably sized hole in the floor for containing the machine in its recessed version.
- Low profile base (**C**) that facilitates the pallet loading and unloading procedure since the turntable is about 2.5 cm above the floor.
- Base with weighing (**D**) that allows the product on the plate to be weighed through the loading cells.
- Base with transpallet and weighing compartment (**E**) that allows loading using a forklift by entering the base compartment, climbing a small distance and weighing the products on the plate.

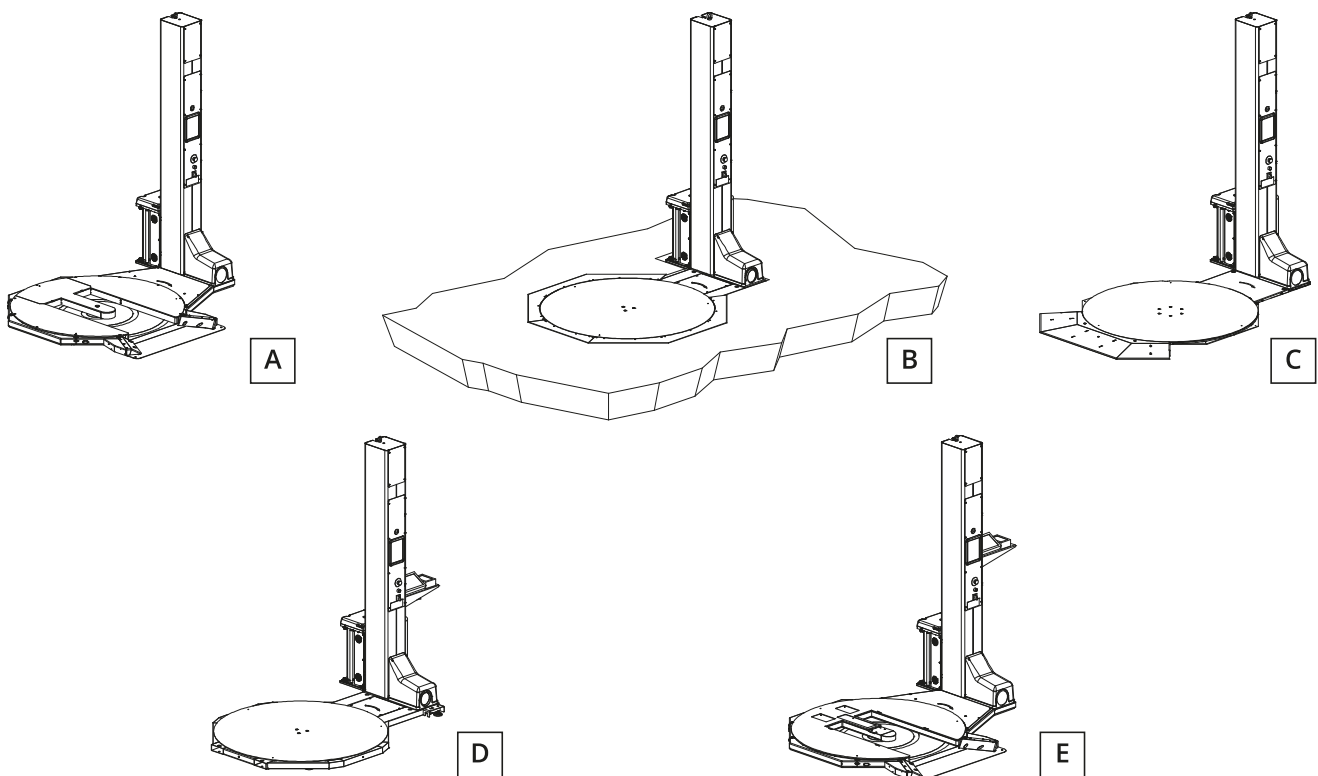

Picture 8

The following optional units can be supplied on request:

- 1) **Lifting frame** that raises the machine off the ground. Allows the table to be loaded using a forklift (electric transpallet) allowing the front wheels to enter under the machine.

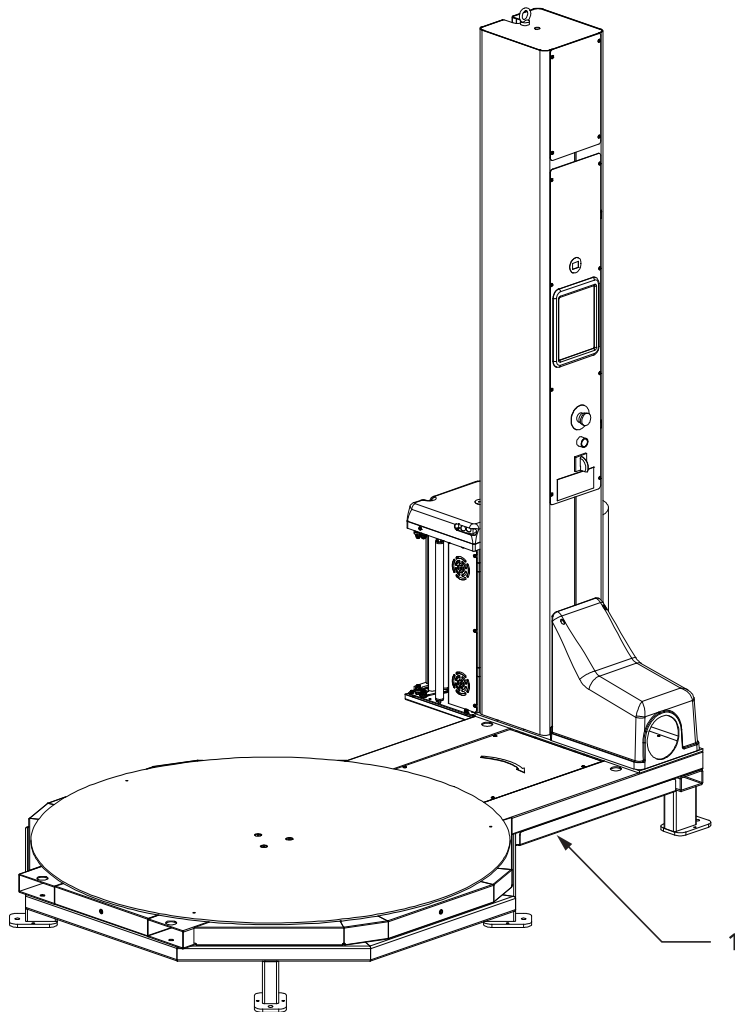

Picture 9

- 2) **Access ramp:** to turntable (not for recessed version). This allows a forklift truck (manual or electric transpallet) to place pallets directly onto the turntable.
- 3) **Presser unit:** is a device that clamps the product on the pallet from above. This device is useful when the product on the pallet is unstable.

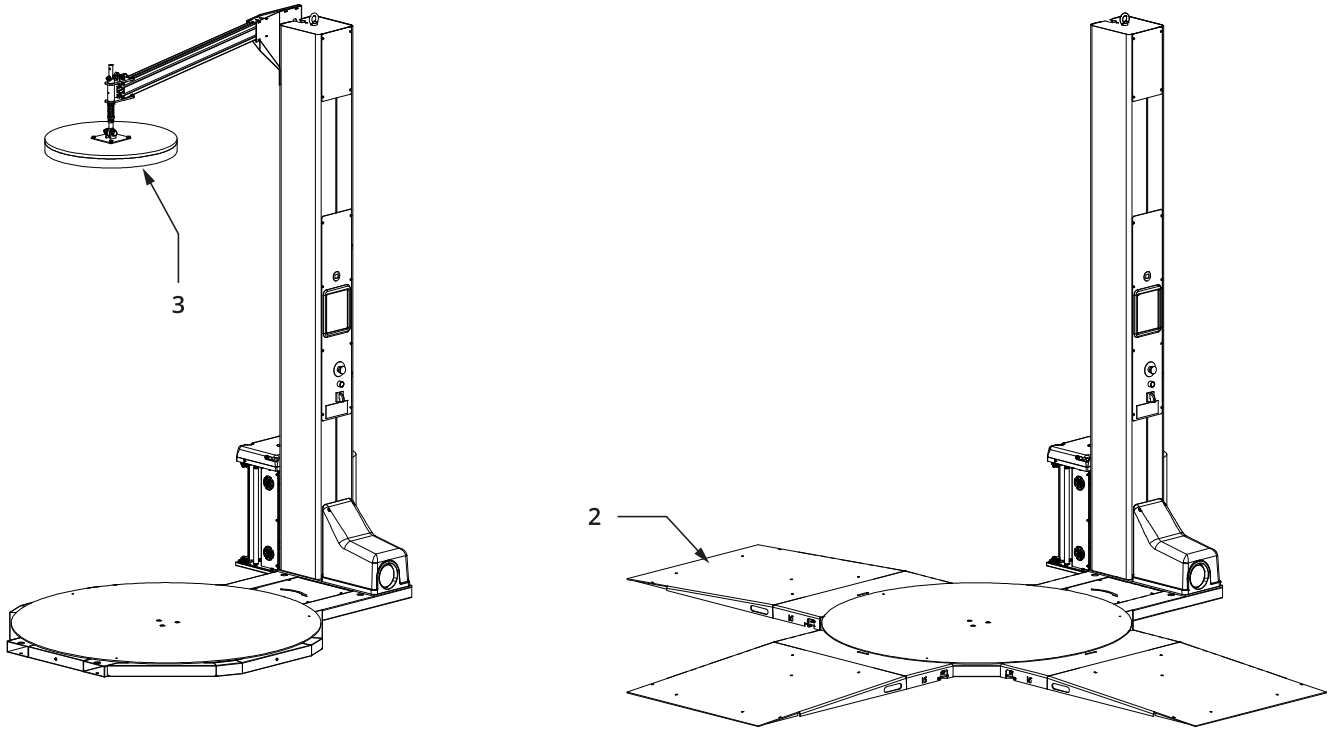

Picture 10

- 4) **The mobile presser** is a device that blocks the product to be palletised from above. It is useful when the product is unstable and very high so it does not interfere during the product loading phase.
- A) Position the product when the presser (**X**) is rotated outside the dimensions of the table.
- B) Before starting the wrapping cycle, the pressing plate (**X**) must be positioned in axis with the table (**Z**).
- C) After the wrapping cycle, the pressing plate (**X**) must be rotated outside the edge of the machine before removing the pallet from the turntable, to avoid impacts to the presser.

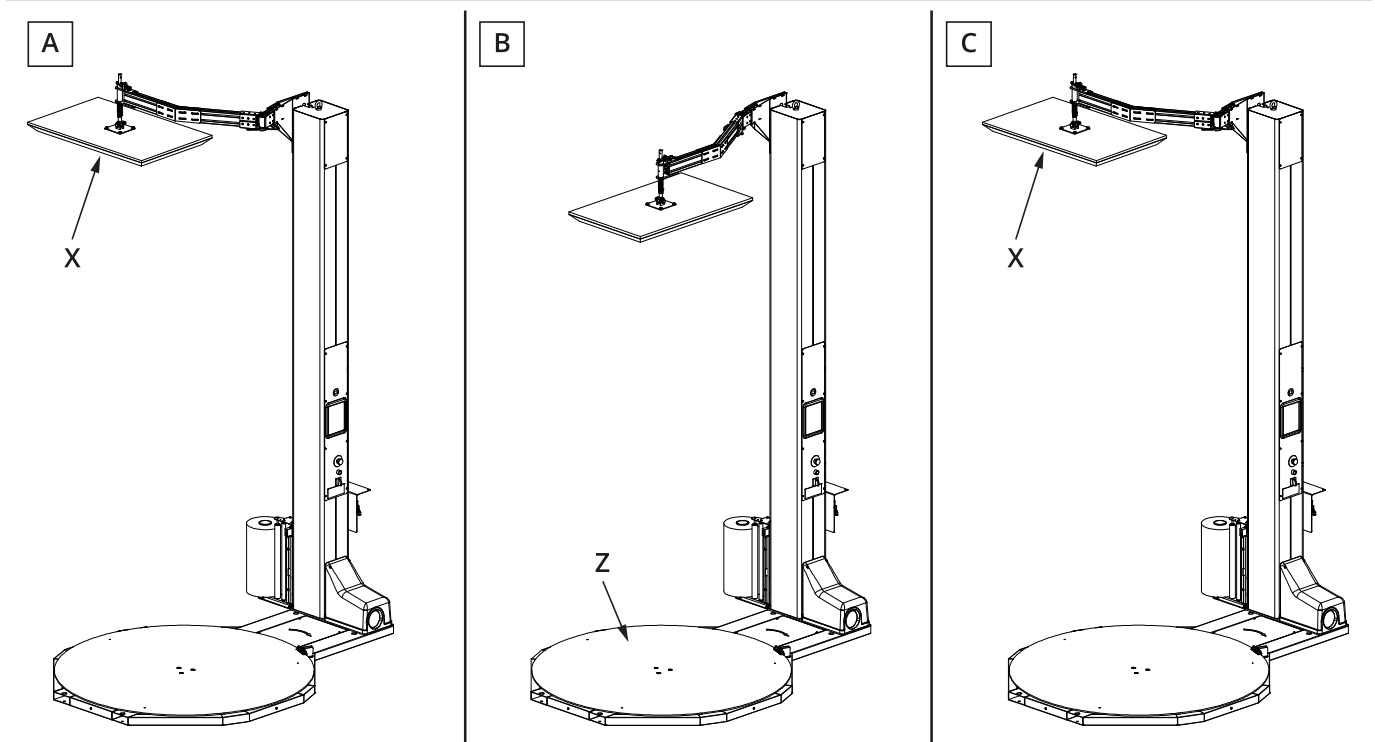

Picture 11

3.2.1 OPTIONAL COMBINATIONS AND CARRIAGE

	EVA	SYNTHESI	SYNTHEX	MYTHO
Carrello FM	X	X		X
FE carriage		X		X
1PRS carriage			X	
PRS-PS carriage				X
Cut		X	X	X
Strip cut			X	X
Strip tightener	X	X	X	X
Automatic strip tightener			X	X
Bubble wrap		X	X	X
Mesh roller	X	X	X	X
Film weighing	X	X	X	X
Ramp	X	X	X	X
Lifting frame	X	X	X	X
Template	X	X	X	X
Carriage guide	X	X	X	X
Presser		X	X	X
Door window		X	X	X

3.2.2 TABLE OPTIONAL EQUIPMENT

3.2.2.1 DOOR WINDOW APPLICATION

This optional device is for packaging doors, shutters, windows, all thin objects and those with low weight, manually loading the product in the containment grippers.

Version with grippers on the plate

Manually position the product to be wrapped above the profile located on the turntable (1), after setting the width of the product to be wrapped, moving the grippers (2) using the levers (3). The operator must keep the product still and press the pedal (4) to lower the upper grippers (5) and lock the product in place. Attach the stretch film and start the wrapping cycle.

At the end of the cycle, the machine stops, maintaining the presser with the upper grippers (5) in position. The operator must cut the stretch film, hold the wrapped product, press the pedal (4) to lift the upper grippers (5) and remove the wrapped product.

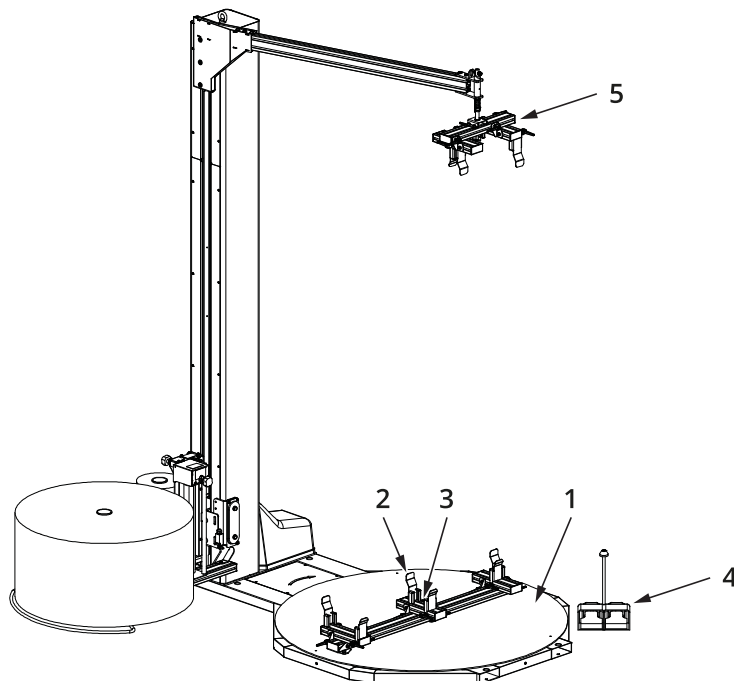

Picture 12

Version with roller unit on the plate

Before starting, check the position of the support pins **(6)** based on the dimensions of the product to be wrapped. If necessary, move them, loosening the screw **(7)** and then tighten it in the desired position.

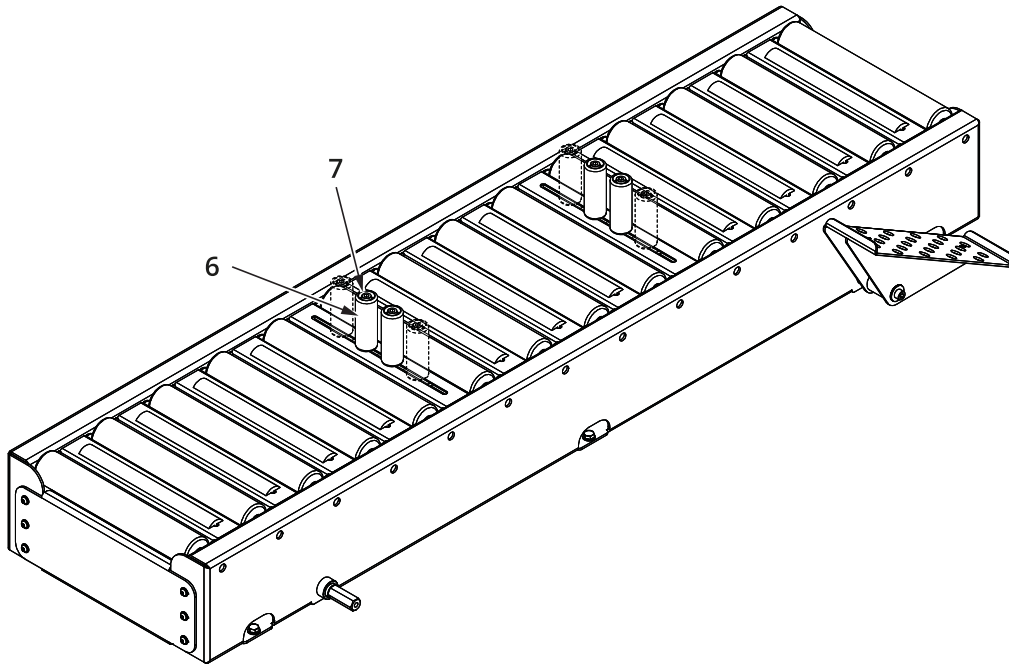

Picture 13

Slide the product to be wrapped above the roller (8) located on the turntable (1) and position it in the middle of the pins (6). The operator must keep the product still and press the pedal (9) to raise the lifter (10), then press the pedal (4) and to lower the upper grippers (5) and lock the product in place. Attach the stretch film to the product and start the wrapping cycle.

At the end of the cycle, the machine stops, maintaining the presser with the upper grippers (5) in position. The operator must cut the stretch film, hold the wrapped product, press the pedal (4) to lift the upper grippers (5) and remove the wrapped product.

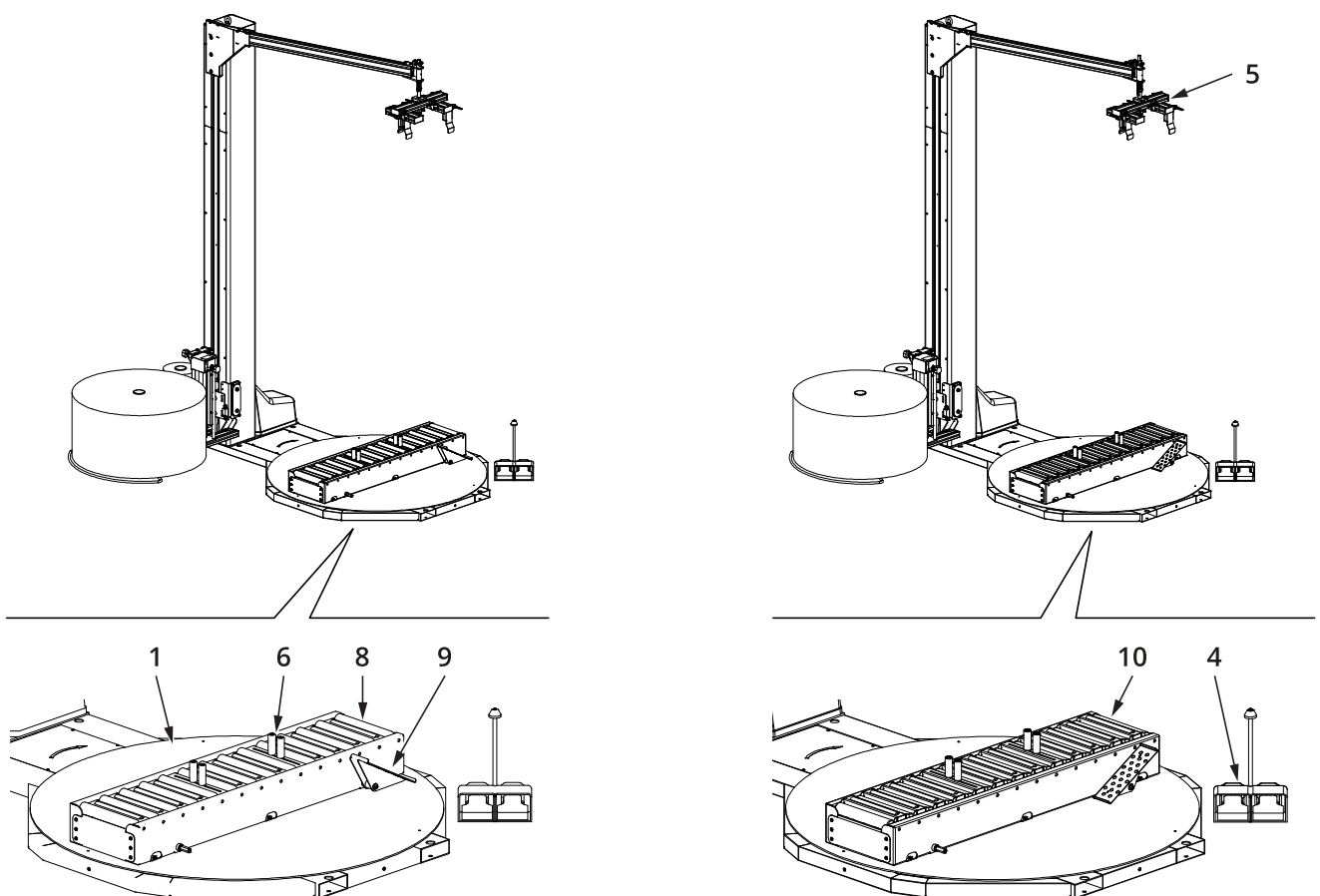

Picture 14

3.2.2.2 CARRIAGE GUIDE (ROLL CONTAINER)

This device helps guide and maintain position during “roll container” carriage wrapping (1).

It is made up of two guides (2) attached to the plate that hold the carriage wheels on the side and a system (3) that blocks their exit during rotation of the turntable.

- A) The operator pushing the carriage along the guides (2) until it reaches the system (3).
- B) Hook the stretch film and start the cycle.
- C) Once the wrapping cycle is complete, cut the stretch film and remove the carriage from the guides (2).

WARNING



Using this system requires a very low rotation speed of the turntable (4) and a very low film tension to prevent the carriage (1) from escaping from the guides (2).

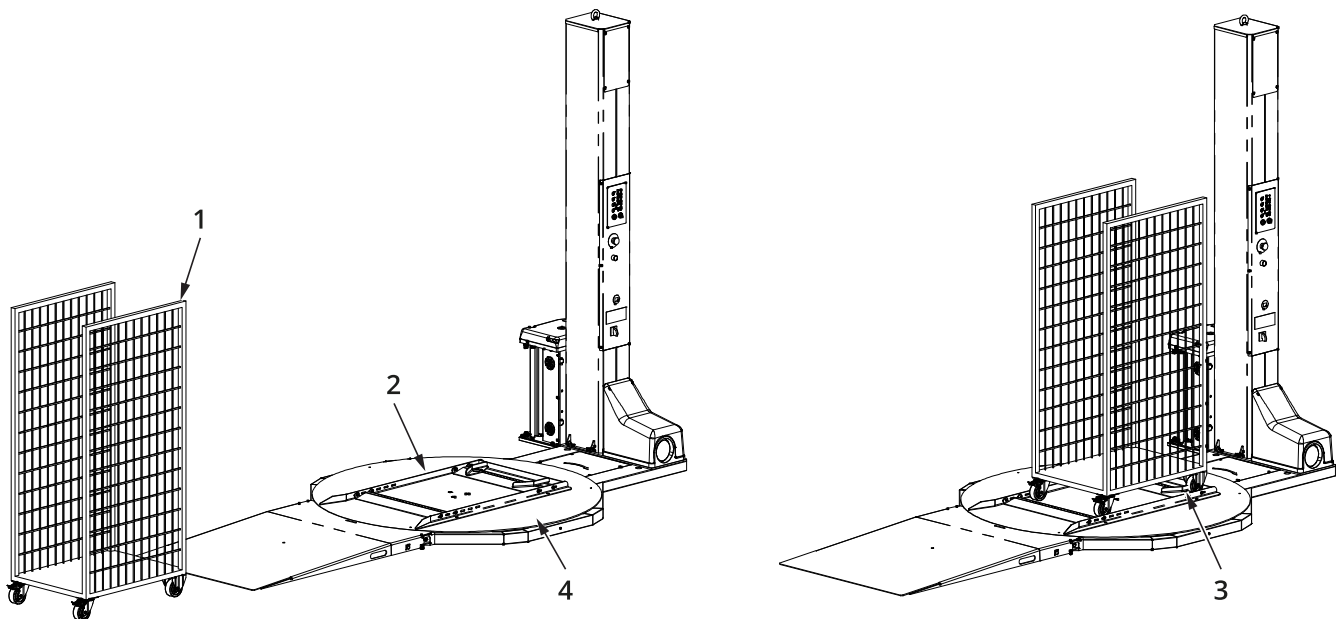

Picture 15

3.3 ROLL-HOLDER CARRIAGE

FM (MB) carriage

» See Picture 16 - pag. 28

With this carriage version, the application tension of the film on the pallet can be adjusted.

The carriage **FM (MB)** is composed of a rubber-coated roller **(1)** and a roller **(2)** with mechanical brake.

The knob **(3)** is used to adjust the action of the brake and, consequently, the tension of the film.

Upon starting, the film must be loaded onto the carriage:

- Put the carriage into the Down position to make fitting the roll easier.
- Turn the main switch to the **'O'-OFF position**.
- Push the roll **(4)** onto the centre pin **(5)**.
- Insert the film between the rollers following the path indicated in figure **(A)**, the symbol with the triangles identifies the side of the film to which the bonding agent (if present) is applied.
- Diagram **(A)** is also attached to the carriage.
- Tightening the knob **(3)** increases the tension of the film, loosening decreases it. Once the proper adjustment has been found, the position of the knob **(3)** is set by tightening the lock nut **(6)**.

Clockwise plate rotation

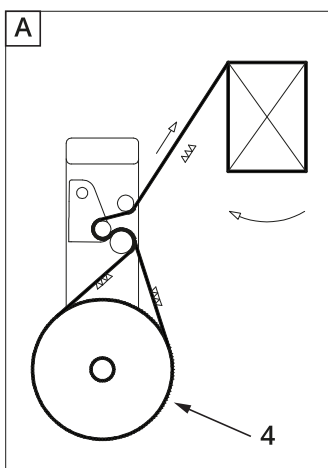

Anti-clockwise plate rotation

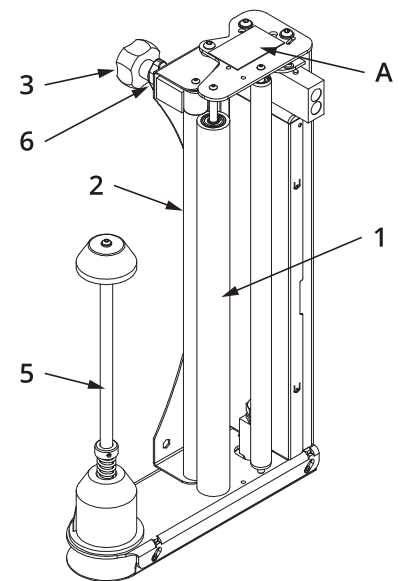
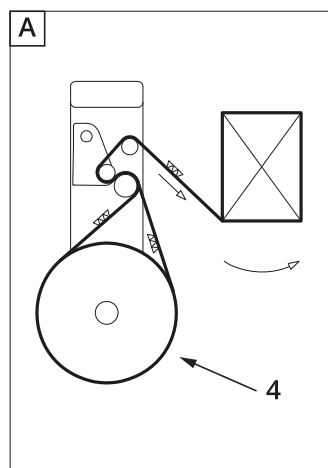

Picture 16

FE (EB) carriage

» See Picture 17 - pag. 29

With this carriage version, the application tension of the film on the pallet can be adjusted.

The **FE** carriage is made up of a rubber idle roller (1) and a roller (2) equipped with an electromagnetic brake.

Setting **F13-16 (F32)** functions in the control panel is used to adjust the action of the brake and, consequently, the tension of the film.

Upon starting, the film must be loaded onto the carriage:

- Put the carriage into the Down position to make fitting the roll easier.
- Turn the main switch to the '**O**'-OFF position.
- Push the roll (4) onto the centre pin (5).
- Insert the film between the rollers following the path indicated in figure (A), the symbol with the triangles identifies the side of the film to which the bonding agent (if present) is applied.
- Diagram (A) is also attached to the carriage.

Clockwise plate rotation

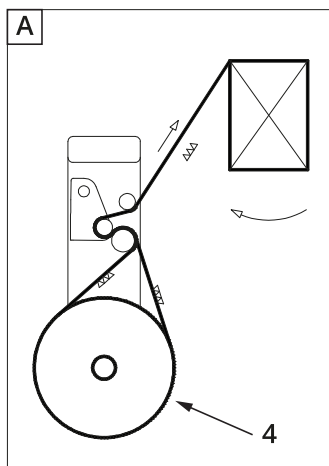

Anti-clockwise plate rotation

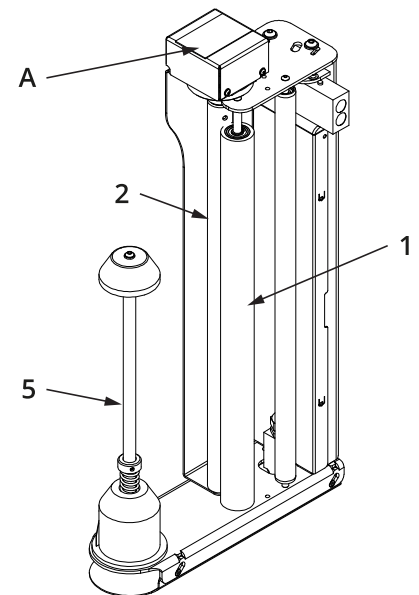
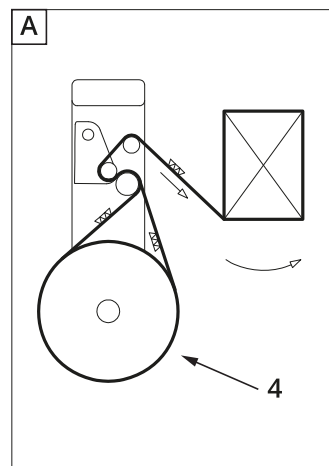

Picture 17

» See Picture 18 - pag. 31

1PRS (EMPS) carriage

With this carriage version, the application tension of the film on the pallet.

This carriage can pre-stretch the film according to fixed ratios determined by interchangeable gears.

The pre-stretch ratios are:

- **150%** (1 metre of film is pre-stretched to a length of 2.5 metres);
- **200%** (1 metre of film is pre-stretched to a length of 3.0 metres);
- **250%** (1 metre of film is pre-stretched to a length of 3.5 metres);
- **300%** (1 metre of film is pre-stretched to a length of 4.0 metres).

The carriage is fitted with a sensor **(4)**, connected to the outlet roller, which measures the tension of the film applied to the pallet.

A specific electronic card integrates the signal of the sensor **(4)** with the adjustment set with setting **F13-16 (F32)** functions in the control panel in order to dynamically control the speed of the pre-stretch roller drive motor and thus the film tension.

The carriage is fitted with a gearmotor which drives three rubber-surfaced rollers **(1)** and **(2)** by means of toothed gearing. The different transmission ratios generate different speeds of the rollers **(1)** and **(2)** creating the pre-stretch action. The carriage also features a set of idle rollers which are used to increase the winding angle of the film on the rubber-coated rollers.

Upon starting, the film must be loaded onto the carriage.

- Put the carriage into the Down position to make fitting the roll easier.
- Push the roll **(7)** onto the centre pin **(8)**.
- Open the door and insert the film between the rollers following the path indicated in figure **(A)**, the symbol with the triangles identifies the side of the film to which the bonding agent (if present) is applied.
- Diagram **(A)** is also attached to the carriage.

To facilitate insertion between the rollers, we recommend squeezing the strip of film into the shape of a rope.

When the reel is in, thread the film behind the first idle roller **(3)** and pull it out at least 50 cm. Thread the rope between the rollers **(1)** and **(2)** at the top of the carriage (at the height of the reduced roller pin) and push it inwards until it comes out behind roller **(2)**; when it extends far enough out to be gripped, simply pull it outwards and arrange it along the last stretch of its route, around the dancer **(4)** and behind the last idle roller **(5)**.

Now, and in this order, use one hand to press the dispenser button **(6)** and your other hand to pull the film.

Clockwise plate rotation

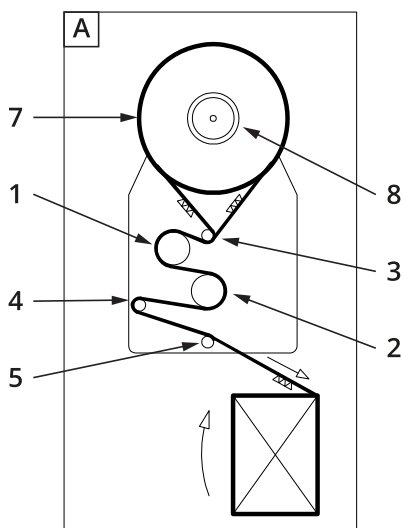

Anti-clockwise plate rotation

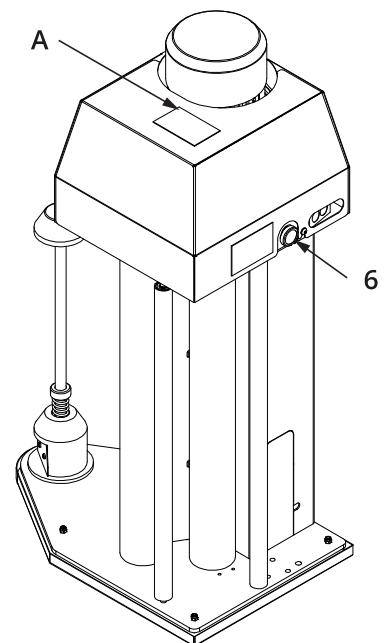
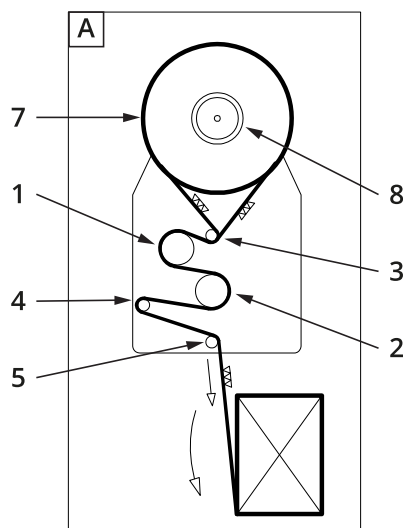

Picture 18

» See Picture 19 - pag. 33

PRS (MPS) carriage

With this carriage version, the application tension of the film on the pallet.

This carriage can pre-stretch the film according to fixed ratios determined by interchangeable gears.

The pre-stretch ratios are:

- **150%** (1 metre of film is pre-stretched to a length of 2.5 metres);
- **200%** (1 metre of film is pre-stretched to a length of 3.0 metres);
- **250%** (1 metre of film is pre-stretched to a length of 3.5 metres);
- **270%** (1 metre of film is pre-stretched to a length of 3.7 metres);
- **300%** (1 metre of film is pre-stretched to a length of 4.0 metres).

The carriage is fitted with a sensor **(4)**, connected to the outlet roller, which measures the tension of the film applied to the pallet.

A specific electronic card integrates the signal of the sensor **(4)** with the adjustment set with setting **F13-16 (F32)** functions in the control panel in order to dynamically control the speed of the pre-stretch roller drive motor and thus the film tension.

The carriage is fitted with a gearmotor which drives three rubber-surfaced rollers **(1)**, **(2)** and **(3)** by means of toothed gearing.

The different transmission ratios generate different speeds of the rollers **(1)**, **(2)** and **(3)** creating the pre-stretch action.

The carriage also features a set of 3 idle rollers which are used to increase the winding angle of the film on the rubber-coated rollers.

Upon starting, the film must be loaded onto the carriage.

- Put the carriage into the Down position to make fitting the roll easier.
- Turn the main switch to the '**O**'-OFF position.
- Push the roll **(7)** onto the centre pin **(8)**.
- Open the door and insert the film between the rollers following the path indicated in figure **(A)**, the symbol with the triangles identifies the side of the film to which the bonding agent (if present) is applied.
- Diagram **(A)** is also attached to the carriage.
- Close the door making sure it is correctly secured.
- Turn the main switch to the '**I**' -ON position.

Clockwise plate rotation

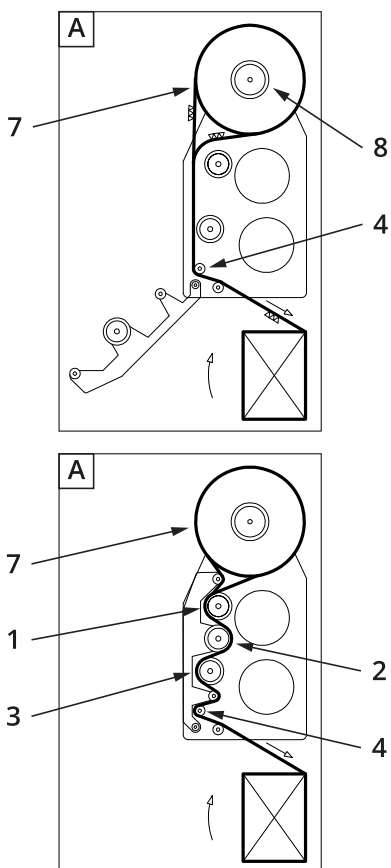

Anti-clockwise plate rotation

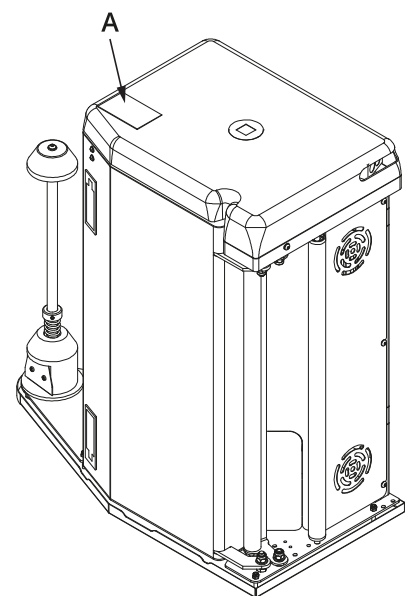
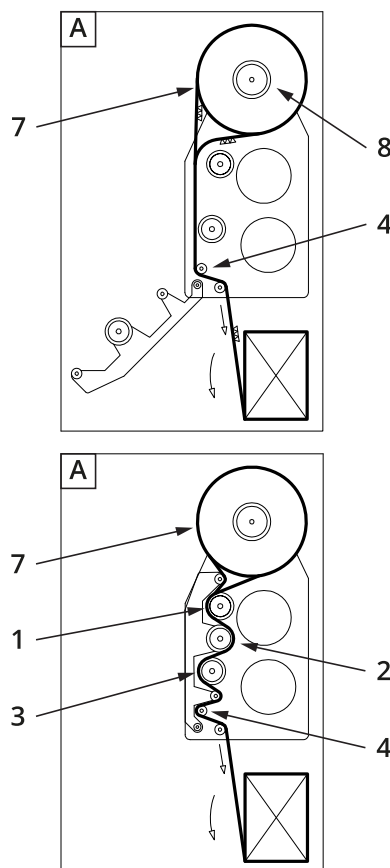

Picture 19

» See Picture 20 - pag. 35

PS (MPS2) carriage

With this carriage version, the tension with which the film is applied to the pallet.

This carriage allows pre-stretching the film. Pre-stretch value can be set between **120%** and **400%**.

The carriage is fitted with:

- a sensor **(4)**, connected to the outfeplied to the pallet;
- two gearmotors which drives the rubber-coated roller **(1)**, **(2)** and **(3)** by means of toothed gearing;
- three idle rollers which are used to increase the winding angle of the film on the rubber-coated rollers.

A specific electronic card integrates the signal of the sensor **(4)** with the adjustment set with setting **F13-16 (F32-33)** functions in the control panel in order to dynamically control the speed of the pre-stretch roller drive motor and thus the film tension.

Can be adjusted using **F17-20** functions in the control panel controls the rotation of the roller **(1)** and **(2)**.

The speed difference generated between the rubber-coated rollers **(1),(2)** and **(3)** creates the pre-stretch action.

Upon starting, the film must be loaded onto the carriage.

- Put the carriage into the down position to make fitting the roll easier.
- Turn the main switch to the '**O**'-OFF position.
- Push the roll **(7)** onto the centre pin **(8)**.
- Open the door and insert the film between the rollers following the path indicated in figure **(A)**, the symbol with the triangles identifies the side of the film to which the bonding agent (if present) is applied.
- Diagram **(A)** is also attached to the carriage.
- Close the door making sure it is correctly secured.
- Turn the main switch to the '**I**' -ON position.

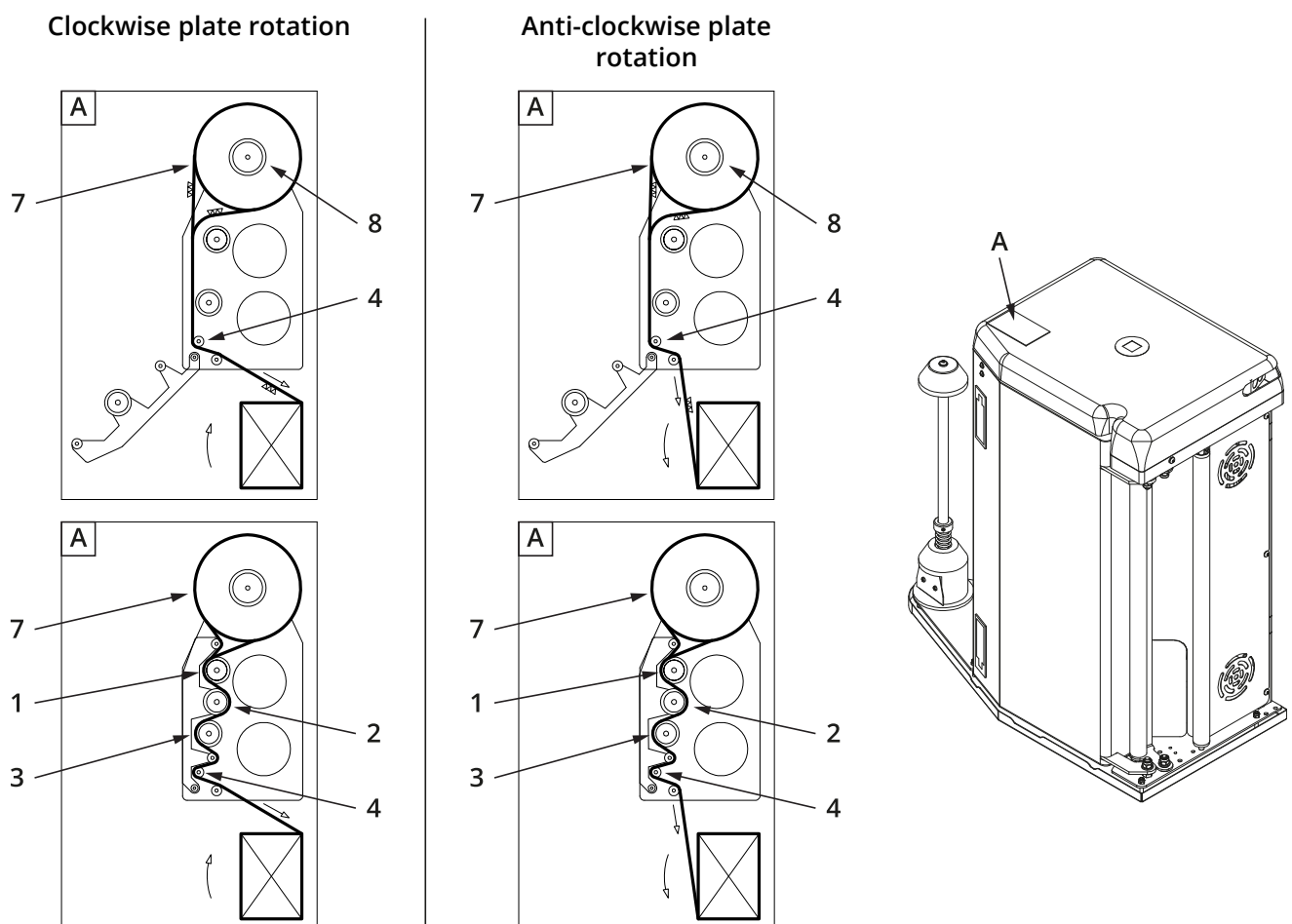

Picture 20

3.3.1 OPTIONAL EQUIPMENT

3.3.1.1 AUTOMATIC CUT

The automatic cycle can be used when the machine is equipped with the cutting unit, for cutting the film at the end of the cycle.

The cutting unit, with the blade **(1)**, includes the film coming out of the carriage and can also be installed after purchase of the machine.

During the last rotation, the roll holder carriage blocks the rollers and after the time set with **F27**, the machine stops, tightening the film, which is cut by the blade the number of times set with **F26**.

After cutting, the machine starts again, the carriage freely dispenses the film for a time set with **F28**, after which it blocks the rollers again, causing the film to break.

WARNING



The optional AUTOMATIC CUTTER and STRIP CUTTER cannot be installed on the machine at the same time; one installation excludes the other.

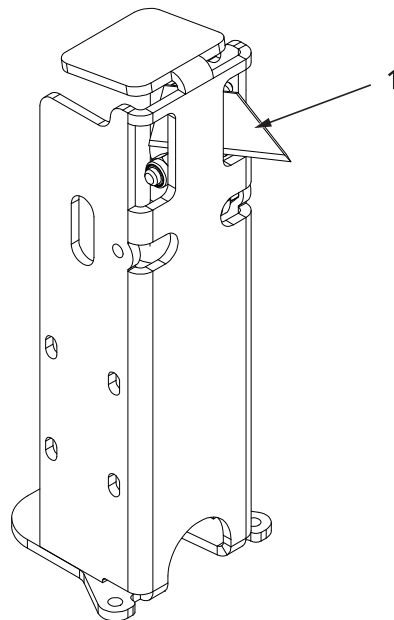

Picture 21

3.3.1.2 STRIP CUT

The strip cutting device can cut the film in 3, 4, or 5 strips, used to stabilize products that need air (e.g., flowers, fruit, etc.) using a common stretch film.

The frame **(1)** has 2, 3, or 4 blades **(2)** that cut the film in the position of the convex wheels **(3)** that keep the stretch film strips separated.

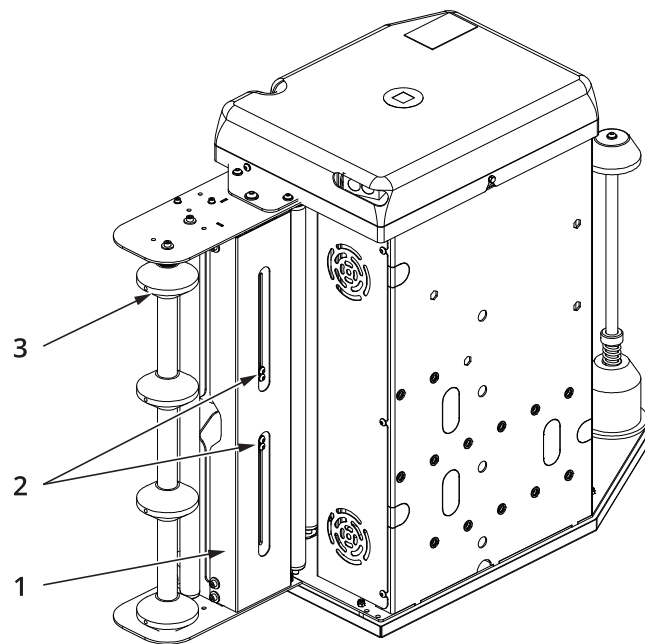

Picture 22

Using the functions that can be set from the control panel, it is possible to configure the wrapping cycle as follows:

F55 include (F55=1) or exclude (F55=0) strip cutting.

F56 delay insertion of the cut (F56=X seconds) at machine startup to being with an whole strip of film.

F57 and **F58** control the cut at the top of the product and exactly:

F57 delays the insertion of the cut (**F57** = X seconds) in descent startup if it was excluded with **F58** = 0.

F58 includes (**F58** = 1) or excludes (**F58** = 0) strip cutting during execution of the top reinforcement rotations.

F59 stops cutting during ascent and shutdown:

- ascending, an amount of time (**F59** = X seconds) after reaching the top of the product, cutting is disabled to move on to the entire strip.
- during shutdown, an amount of time (**F59** = X seconds) after the rotation starts to slow down, cutting is disabled, allowing the last segment of stretch film to exit unsectioned from the pre-stretch carriage for easier control.

If you want to wrap the top part of the product by overflowing the film beyond the top of the product itself, it is recommended to do so with the stretch film not cut into strips, the stretch film must be one entire strip; so, set **F58** = **0** and **F57** = X.

If, on the other hand, you do not want to overflow the top, it is also possible to cut the film into strips during the reinforcement rotations at the top, including cutting during this phase (**F58** = **1**).

WARNING



*The optional **AUTOMATIC CUTTER** and **STRIP CUTTER** cannot be installed on the machine at the same time; one installation excludes the other.*

3.3.1.3 STRIP TIGHTENER (MANUAL VERSION)

The manual strip tightener (1) reduces the width of the film to one string and reinforces binding of the product. It can also be installed later, attaching it as in the image below.

The device is comprised of a frame (2) in which the grooved wheel (4) slides, with the help of a lever (3), reducing the width of the stretch film.

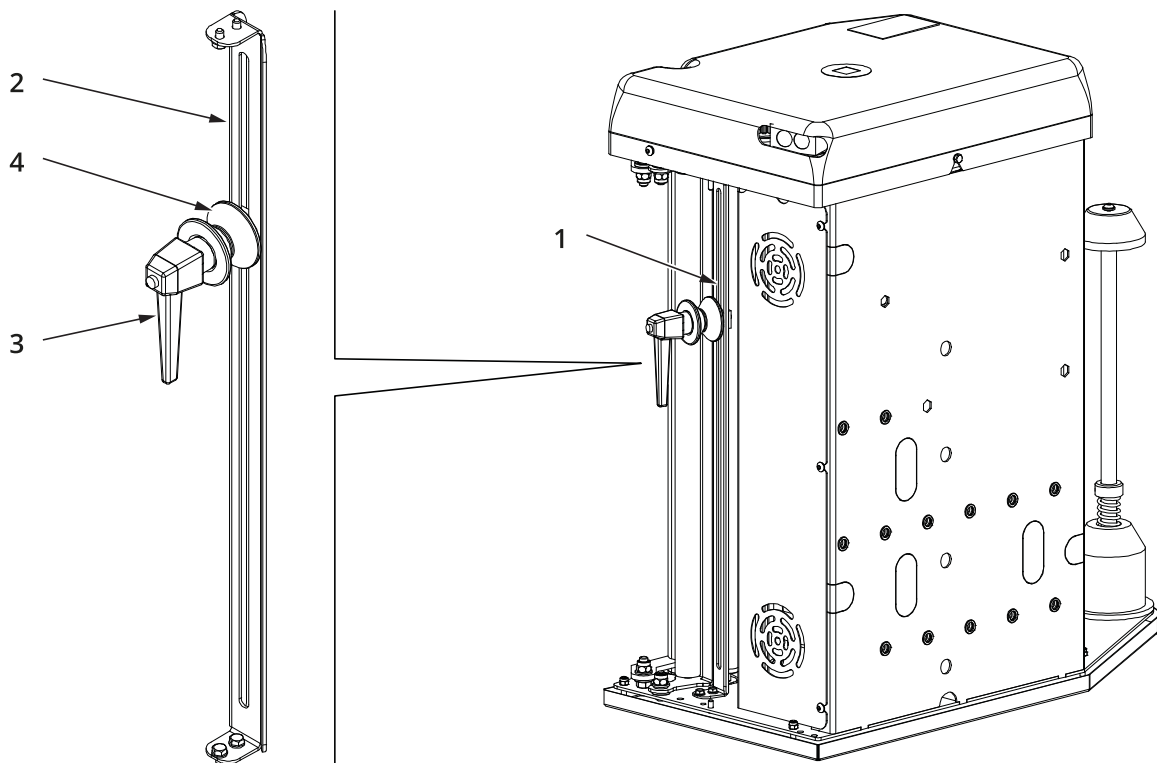

Picture 23

3.3.1.4 STRIP TIGHTENER (AUTOMATIC VERSION)

The automatic strip tightener reduces the width of the film to one string and reinforces binding of the product.

SINGLE AUTOMATIC STRIP TIGHTENER

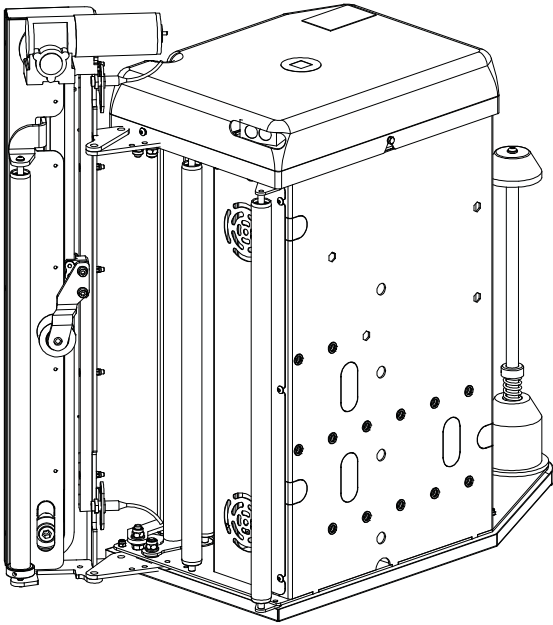

DOUBLE AUTOMATIC STRIP TIGHTENER

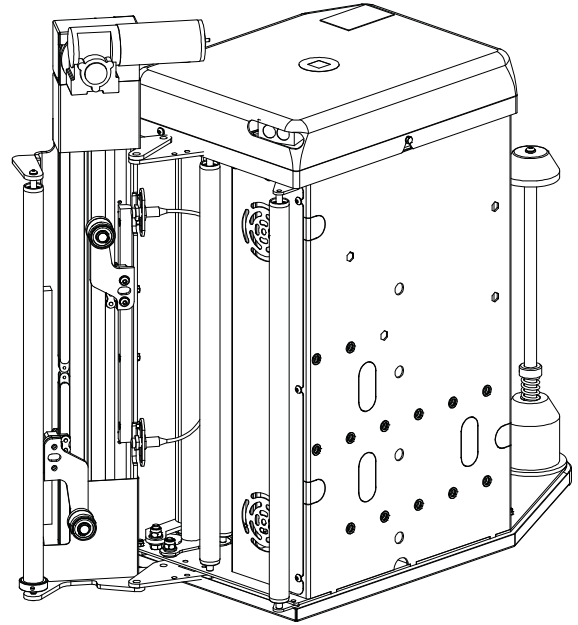

Picture 24

The device is made up of a frame **(1)** with a chain ring **(2)** controlled by a gear motor **(3)**. The same frame has an idle roller **(4)** that forces the film to follow a certain path; see diagram **(A)**. Attached to the chain **(2)** is a grooved idle wheel **(6)** (or two in the case of a double strip tightener).

Operating the gear motor **(3)**, the chain **(2)** moves the grooved idle wheel **(6)** (or the two wheels in the case of the double strip tightener) vertically. When it encounters the strip of stretch film, it reduces the film width to a string.

The frame **(1)** has two sensors:

- sensor **(7)** stops the grooved wheel **(6)** in the bottom position that corresponds to the strip of stretch film reduced to a string.
- sensor **(8)** stops the grooved wheel **(6)** in the top position that corresponds to the extended strip of stretch film.

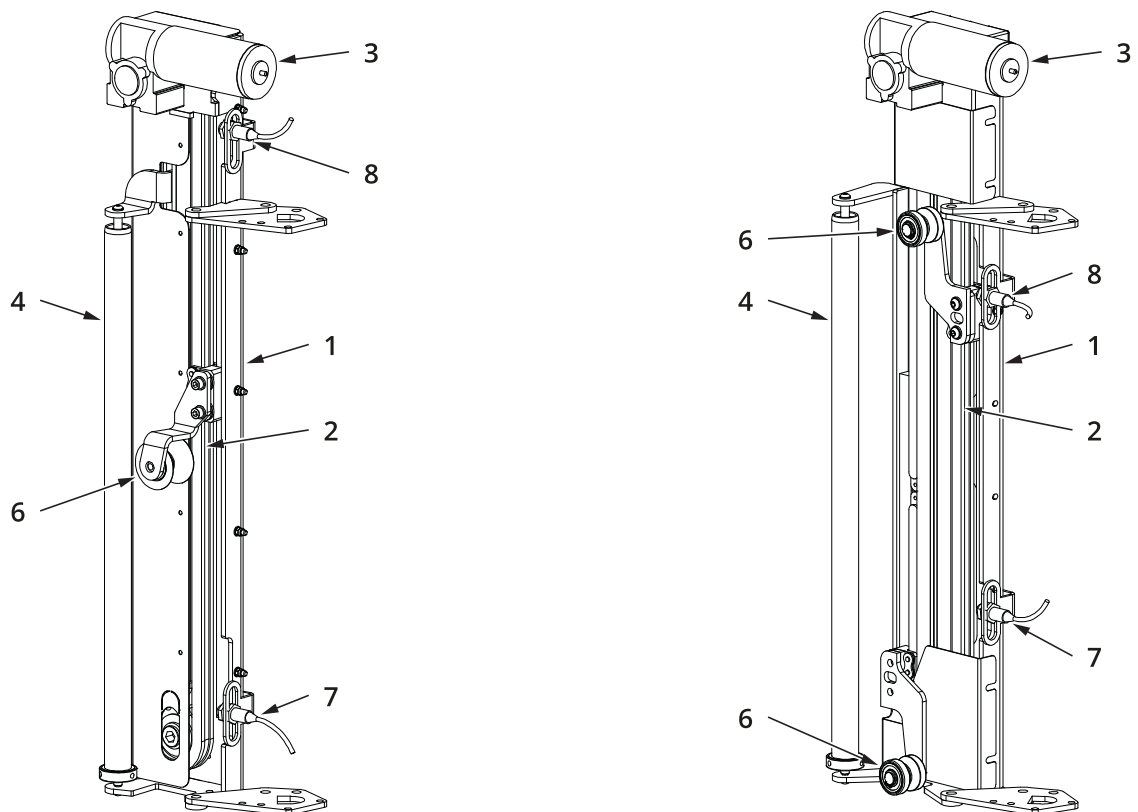

Picture 25

Open the door and insert the film between the rollers following the path indicated in figure (A), the symbol with the triangles identifies the side of the film to which the bonding agent (if present) is applied.

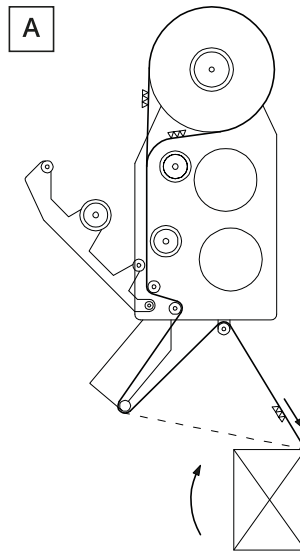

Picture 26

Using the functions that can be set from the panel, the following is possible:

- Exclude **(F34=0)** or include the device and choose the number of rotations **X** at the base of the product **(F34=X)**.
- Exclude **(F36=0)** or include the device and choose the number of rotations **X** at the top of the product **(F36=X)**.
- Exclude **(F35=0)** or include the device during carriage ascent **(F35=1** for the entire ascent, **F35=2** up to the reinforcement* excluded, **F35=3** from the reinforcement to the upper rotations and **F35=4** only during reinforcement*).
- Exclude **(F37=0)** or include the device **(F37=1)** during carriage descent.
- Choose the final number of bottom rotations **(F38=X)**.
- Choose the reduction of the film strip, setting the adjustment time **(F39=X)**.
- Enable the ascent of the carriage with the device included at the top of the product after performing the upper rotations with film open **(F63=X)**.

(*) reinforcement set with **F7** and **F8**.

3.3.1.5 BUBBLE WRAP

This option is used to ensure greater protection of the product.

A carriage **(1)** is added that holds the roll of bubble wrap that is applied between the product and the stretch film.

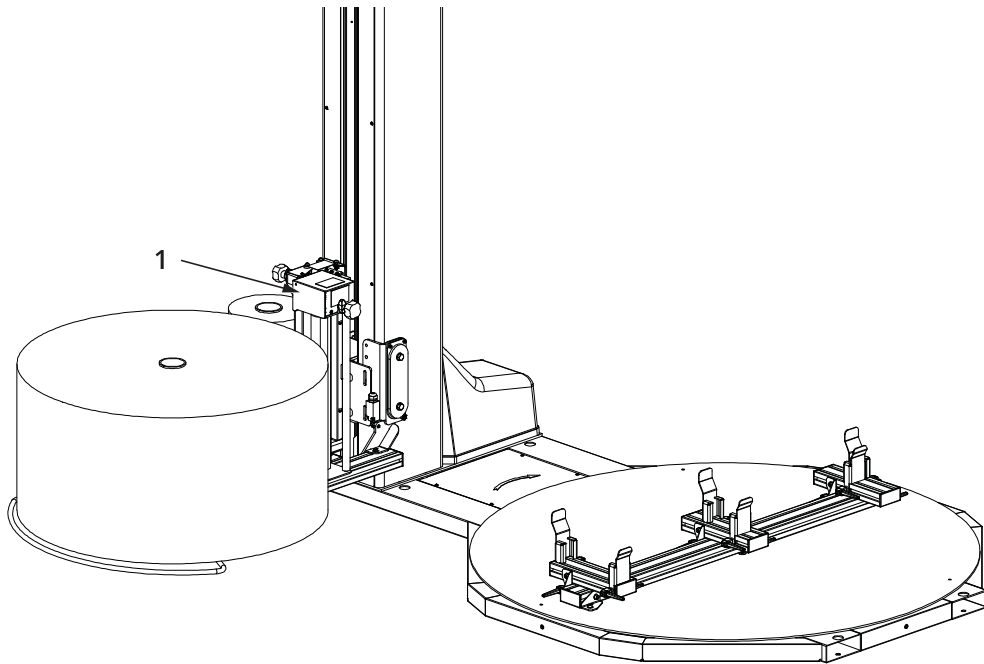

Picture 27

3.3.1.6 MESH ROLLER

The mesh roller allows the products to be wrapped using rolls of polyethylene mesh **(1)**.

This material is highly indicated for wrapping products that need ventilation. Ventilation is ensured even with a high number of layers necessary to ensure product stability.

The mesh roller keeps the mesh tight between the product and the roll, without stretching it.

The optional mesh roller is comprised of a roll holder shaft **(2)** with a braking system plus a roller **(3)** with a special external finish, both of which are mounted in place of the standard ones.

The roll holder shaft **(2)** brakes the rotation of the roll **(1)** to ensure greater grip of the roller **(3)** on the mesh. The braked roller, grips the links of the mesh and tightens it towards the product.

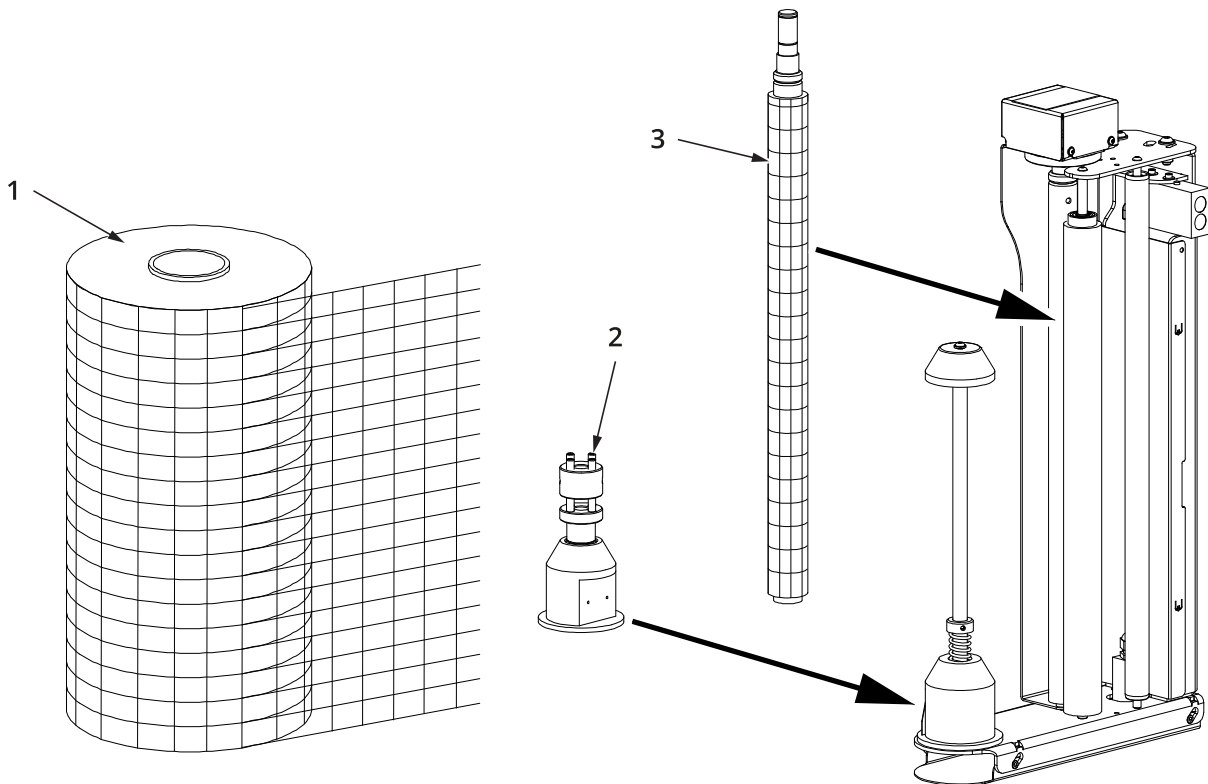

Picture 28

3.3.1.7 FILM WEIGHING

Film weighing calculates the amount of stretch film used to wrap each product, which is expressed in grams or metres.

At the end of each cycle, the machine will indicate the film consumption, showing "LF" on the screen (if expressed in metres) or **WF** (if expressed in grams) and the quantity of metres or grams on the screen (**V**).

INFORMATION



If the weight is expressed in grams, to obtain good precision, correctly set the thickness of the film in microns (from 8 to 40) in the parameter F24.

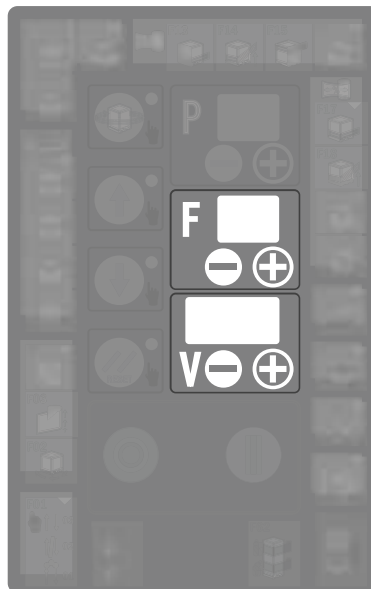

Picture 29

3.4 INTENDED USE - PROPER USE - PURPOSE

The wrapping machine, designed to be anchored to the ground, has been designed and constructed for wrapping various types of products stacked on pallets with stretch film, in order to stabilise the package and to protect it from damp and dust during transport and storage.

Using a lifting apparatus, the pallet with the products to be wrapped is placed on the turntable; the stretch film is applied by means of a dedicated carriage which moves on the vertical axis according to the height of the product to be wrapped.

Working limitations

For safety reasons suitable working limitations have been imposed, in keeping with the size of the machine and the relative turntable. The products to be wrapped must be within the working limits of the machine in your possession, specified in terms of maximum load and maximum dimensions, on the basis of the turntable diameter (\emptyset), as indicated in the table.

Stretch film

Use a film of specification suitable for the type of carriage available and for the type of packaging application for which the machine was intended; always evaluate the choice of film in relation to its safety sheet.

Use a perforated film if the wrapped products require ventilation otherwise they will generate condensation (fresh organic products: fruit, vegetables, plants, etc...).

Use a blackout film for the protection of light-sensitive products.

Max. dimension of the Product to be wrapped

Base version	Ø	X	Z	STD	STD	STD	OPT	OPT	OPT	W (kg)
				2200	2500	2700	3200	3500	3900	
Standard	1500	1200	800							
	1650	1200	1000							
	1800	1200	1200	2200	2500	2700	3200	3500	3900	2000
		1400	1000							
	2200	1550	1550							
1900		1000								
Riveted	1500	1200	800	2200	-	-	-	-	-	1500
	1650	1200	1000		-	-	-	-	-	
Transpallet	1650	1200	1000	2200	2500	2700	3200	3500	3900	1200
	1800	1200	1200							
Low profile	1650	1200	1000	2200	2500	2700	3200	3500	3900	1200

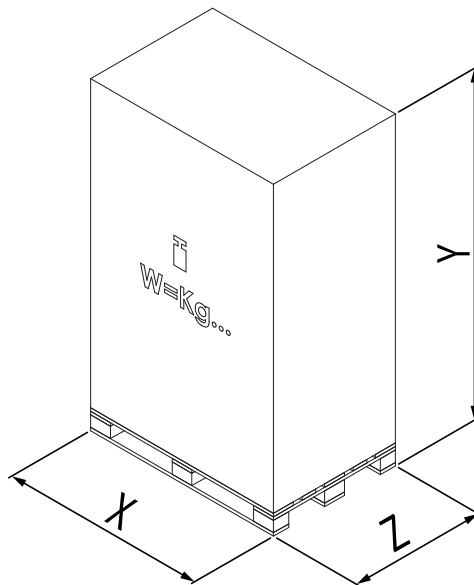

Picture 30

3.5 UNINTENDED AND UNAUTHORISED USE - FORESEEABLE AND UNFORESEEABLE IMPROPER USE

Use of the pallet wrapping machine for unauthorised purposes, its improper use and lack of maintenance can lead to the risk of serious danger to health and safety of operators and exposed persons, as well as affecting the working efficiency and safety of the machine.

The following is a list of some possible, reasonably more foreseeable, examples of "bad usage" of the machine.

- NEVER allow anyone to climb onto the turntable.
- NEVER start the work cycle when there is anyone in the immediate vicinity of the machine.
- NEVER allow the machine to be used by unauthorised persons or by minors under the age of 16.
- NEVER leave the control station during the working process.
- NEVER load onto the machine containers that have toxic, corrosive, explosive or flammable products.
- NEVER start the work cycle if the load is not centred properly on the turntable.
- NEVER start the work cycle if the product loaded is tied outside the machine.
- NEVER use the machine outdoors or under not permitted environmental conditions.

3.6 TECHNICAL DATA AND NOISE

- Overall dimensions	See Picture 31 - pag. 51
- Net weight of machine body	350 kg
- Supply voltage	230 Volt
- Frequency	50/60 Hz
- Phases	(single-phase + neutral + earth)
- Nominal current	6 A
- Power installed	1 kW (std) 1,2 kW (PS carriage)
- Stretch film	17/30 μ m
- Roll-holder tube inside \emptyset	76 mm
- Roll height	500 mm
- Maximum roll weight	16 kg
- Carriage speed	1 \div 4 m/min
- Turntable speed min. \div max.	4 \div 12 rpm

Noise

In observance of annex 1 of machine directive 2006/42/EC, the manufacturer declares that the noise emitted by the machine in question falls within the limits established by the above mentioned regulations 70 dB(A).

MACHINE DIMENSIONS										RAMP DIMENSIONS	
\emptyset	A	B	D	E	F	Std 2500	Opt 3000	Opt 3300	Opt 3700	H	I
1500	1510	2350	2700	75	1400	2800	3300	3600	4000	1000	1500
1650	1660	2350	2700								
1800	1810	2650	3000								
2200	2230	3050	3400								

PRESSER DIMENSIONS													
Std	Opt	Opt	Opt	Std	Opt	Opt	Opt		Std	Opt	Opt	Opt	
2500	3000	3300	3700	2500	3000	3300	3700		2500	3000	3300	3700	
L	L	L	L	M	M	M	M	N	O	O	O	O	
2750	3250	3550	3950	2100	2600	2900	3300	500	2100	2600	2900	3300	

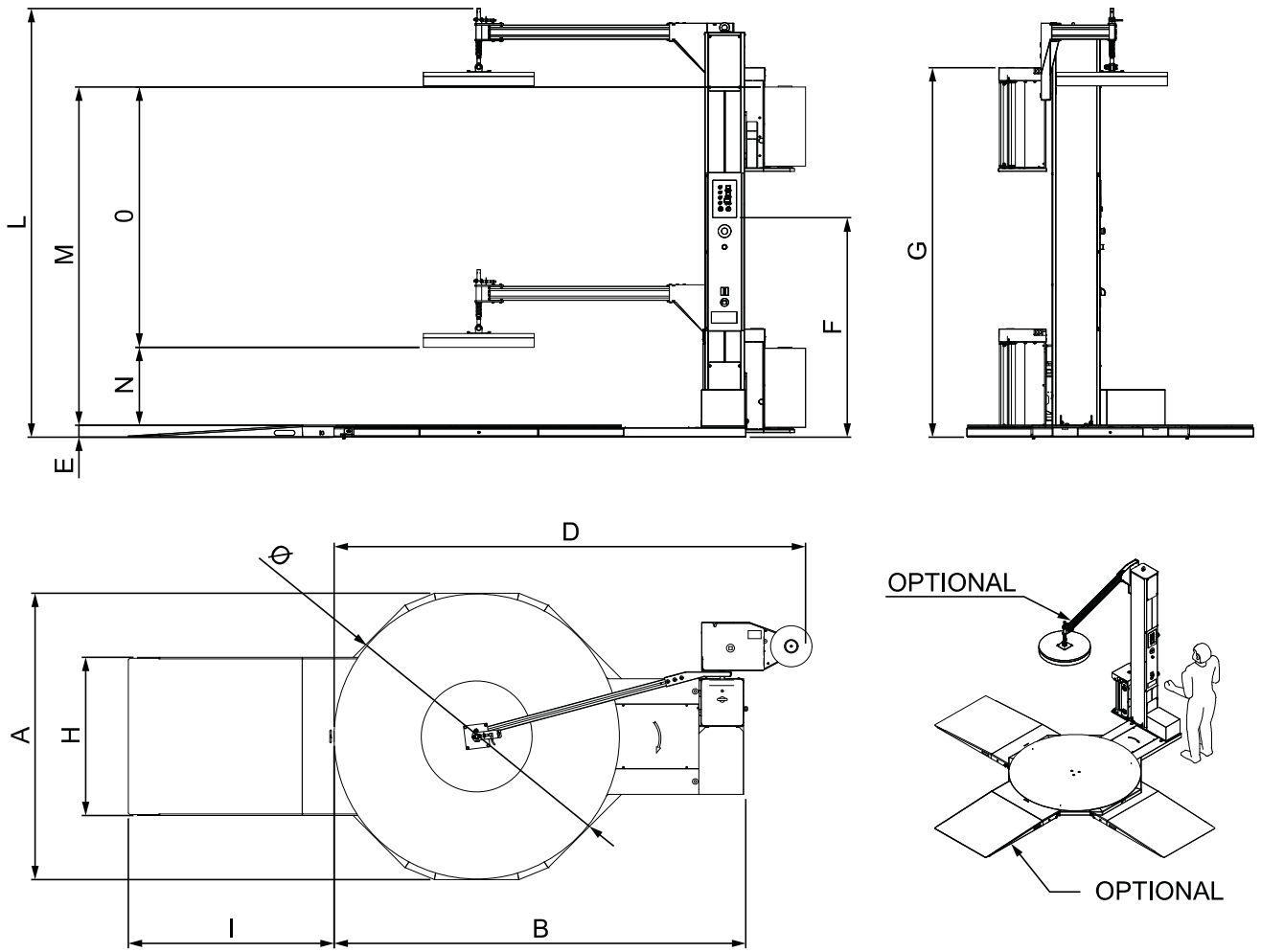

Picture 31

» See Picture 32 - pag. 53

3.7 WORK AND CONTROL STATIONS

STATION A - Control area

The operator must be at this station when the machine is carrying out a wrapping cycle.

It is the station from where the operator starts and stops the machine and changes the machine working modes. It also allows visual surveillance of the work cycle, so that the operator can activate the emergency stop device in the event of potentially dangerous situations.

STATION B - Work area

In the work area the operator carries out the following operations:

- attaches the film to a corner of the pallet to start the work cycle;
- cuts the film at the end of the work cycle.

DANGER



Attaching and cutting the film must be done with the machine cycle stopped and the turntable not moving.

STATION C - maintenance area

In the maintenance area the operator carries out the following operations:

- changes the film roll;
- adjusts the film tension, if mounted on the carriage.

WARNING



All operations that can be performed in station "C" must be carried out with the turntable fully down and the machine stopped.

DANGER



IT IS FORBIDDEN TO CROSS THE CENTRAL MACHINE AREA MARKED AS "D".

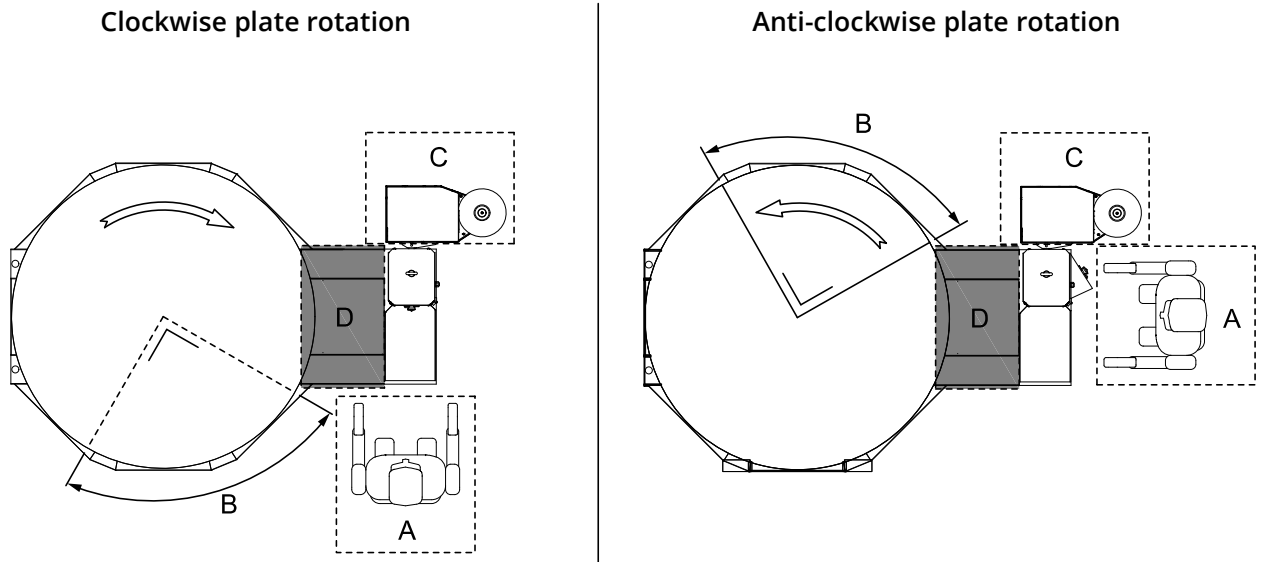

Picture 32

4 TRANSPORT-HANDLING-STORAGE

4.1 PACKING AND UNPACKING

The machine may be shipped in different ways depending on the transport requirements:

- Machine on a wooden pallet and protected by transparent plastic wrapping.
- Machine packed in a wooden crate of suitable dimensions.
- Machine on wooden base and protected by a cage of wooden crossbars.

Upon receipt, check that the packaging has not been damaged during transport or that it has not been tampered with and parts removed. Move the packed machine as close as possible to the place of installation and start unpacking, carefully checking that the supply corresponds to the order specifications.

DANGER



The lifting and transport means must be chosen based on the size, weight and shape of the machine and its components. The capacity of the lifting equipment must be greater (with a safety margin) than the weight of the components to be transported.

N.B.: If damaged or missing parts are found, immediately notify Customer Service and the carrier, providing photographic documentation.

Make sure that no small parts are left in the packaging.

Make a detailed examination of the general conditions of the machine.

The various packing materials must be disposed of in accordance with current environmental protection regulations.

WARNING



During unloading and handling operations, an assistant must be on hand to give any necessary directions during transport.

WARNING



THE MANUFACTURER declines all responsibility for damage caused by incorrect operations, unqualified personnel or the use of unsuitable means.

4.2 TRANSPORTING AND HANDLING THE PACKED MACHINE

WARNING



EXCLUSIVELY use a forklift truck of adequate capacity to lift and transport the **PACKED** machine. **USING ANY OTHER SYSTEM WILL NULLIFY THE WARRANTY FOR ANY DAMAGE CAUSED TO THE MACHINE.**

INFORMATION



THE WEIGHT OF THE PACKAGING IS GENERALLY INDICATED ON THE OUTSIDE.

DANGER



ALWAYS CHECK BEFORE ANY OPERATION THAT THERE ARE NO EXPOSED PERSONS IN HAZARDOUS ZONES (IN THIS CASE THE ENTIRE ZONE AROUND THE MACHINE PARTS IS TO BE CONSIDERED A HAZARDOUS ZONE).

Package dimensions: 2900x2000x550 mm

Package weight: 600 kg

* STD machine

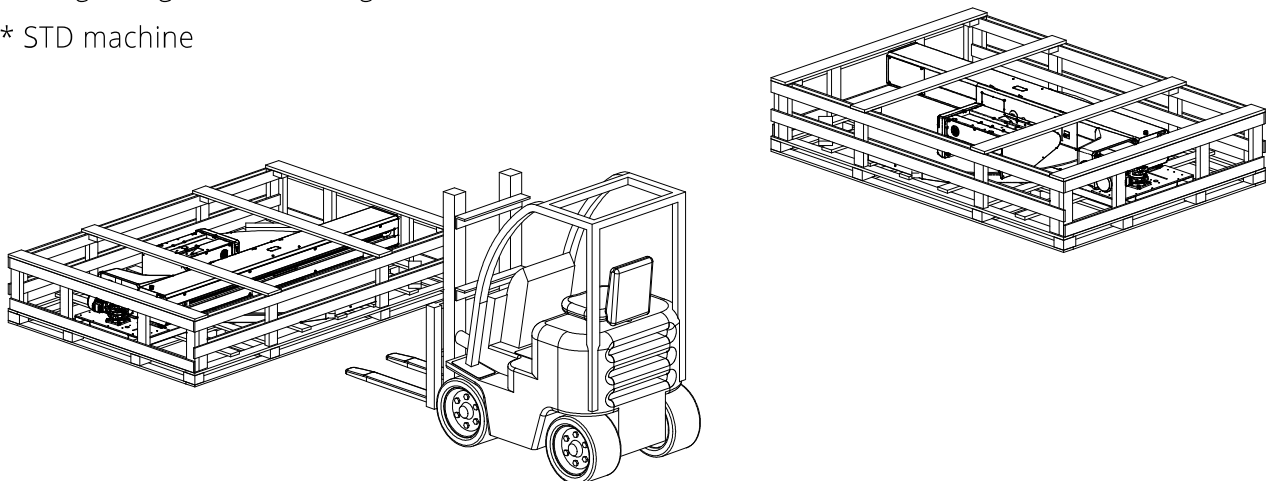

Picture 33

4.3 TRANSPORTING AND HANDLING THE UNPACKED MACHINE

» See Picture 34 - pag. 56

- Free the machine from the packaging as shown in the figure.
- Carefully insert the forks of the forklift into the rails **(A)**, marked with the pictogram **(B)**, to the maximum possible depth.
- Lift and transfer the machine to the installation location.

WARNING



EXCLUSIVELY USE A FORKLIFT TRUCK OF ADEQUATE CAPACITY TO LIFT AND TRANSPORT THE MACHINE. USING ANY OTHER SYSTEM WILL NULLIFY THE WARRANTY FOR ANY DAMAGE CAUSED TO THE MACHINE.

DANGER



THE RISK OF IMPACT IN ANY CASE REMAINS, CAUSED BY SUDDEN MOVEMENT DUE TO UNBALANCING OF THE MACHINE PARTS IN THE EVENT THAT THE BELTS SAG OR SLIP. LIFT THE MACHINE SLOWLY AND SMOOTHLY (WITHOUT JERKING OR PULSES).

DANGER



ALWAYS CHECK, BEFORE ANY OPERATION, THAT THERE ARE NO EXPOSED PERSONS IN HAZARDOUS ZONES (IN THIS CASE THE ENTIRE ZONE SURROUNDING THE PALLETS IS TO BE CONSIDERED AS A HAZARDOUS ZONE).

Net weight: 500 kg

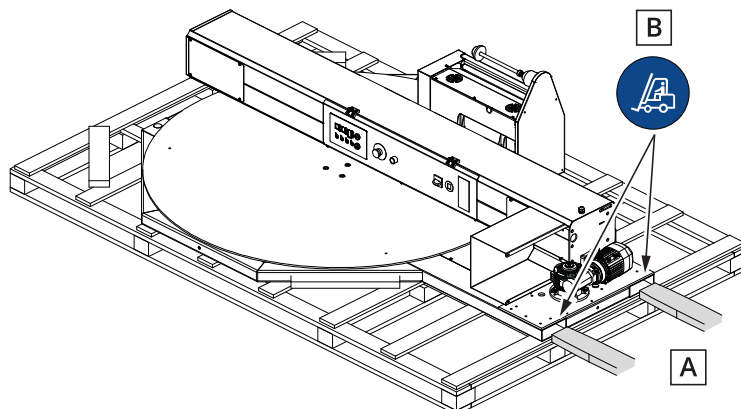

Picture 34

To lift the machine, proceed as follows:

» See Picture 35 - pag. 57

- Carefully insert the forks of the forklift into the rails (**A**), marked with the pictogram (**B**), to the maximum possible depth.
- Lift and transport the machine.

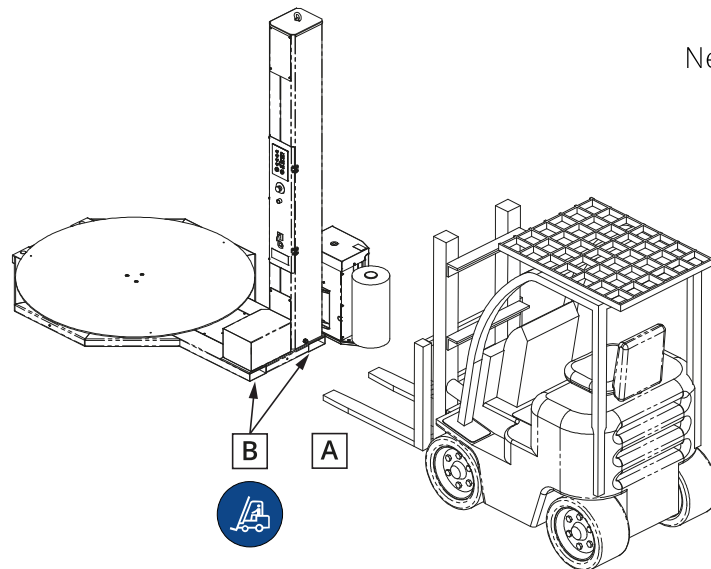

Picture 35

WARNING



The machine with low profile base cannot be moved when assembled.

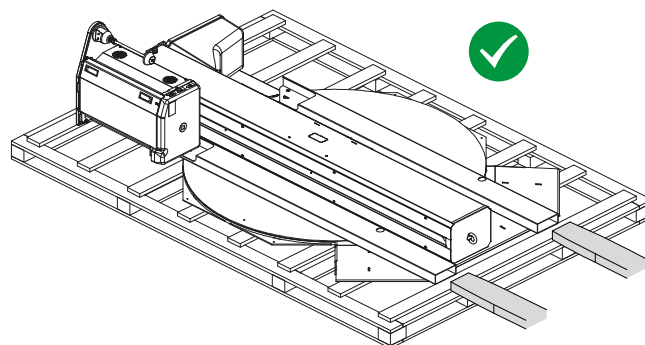

Picture 36

4.4 STORAGE OF PACKED AND UNPACKED MACHINE

In the event of long periods of inactivity, the customer must check the place where the machine is positioned and depending on the type of packaging (crate, container, etc.), ensure that the storage conditions are suitable.

If the machine is not used and stored in a place according to the technical specifications, the sliding parts must be greased. In case of doubt, contact Customer Service.

The manufacturer declines all responsibility if the user does not specify or request the above information.

5 INSTALLATION

5.1 PERMITTED AMBIENT CONDITIONS

Temperature:

For regular operation of the machine, the ambient temperature must be between +5°C and +45°C.

Atmospheric conditions:

The electrical equipment is able to function correctly in atmospheric conditions with relative humidity not greater than 50% at a temperature of 40°C and 90% at a temperature not over 20°C (without condensation). If the atmospheric conditions are not suitable for machine operation, the Manufacturer can, on request, provide solutions to remedy the problem (e.g. air conditioners, thermostatic heating elements, etc.).

Lighting:

Minimum necessary and indispensable illumination: 300-500 lux.

DANGER



The standard machine is not designed or set up for operation in places with an explosive atmosphere or risk of fire.

5.2 USE AND MAINTENANCE CLEARANCES

» See Picture 37 - pag. 61

The largest free space must be provided on the side of the turntable used for loading and unloading, there must also be sufficient space for movement of forklift trucks or other equipment necessary for maintenance work and for loading the rolls of film.

The remaining sides of the machine must be placed as far as possible up against side walls or fixed barriers, to prevent easy access.

Reference should always be made to the layout agreed with the manufacturer upon ordering.

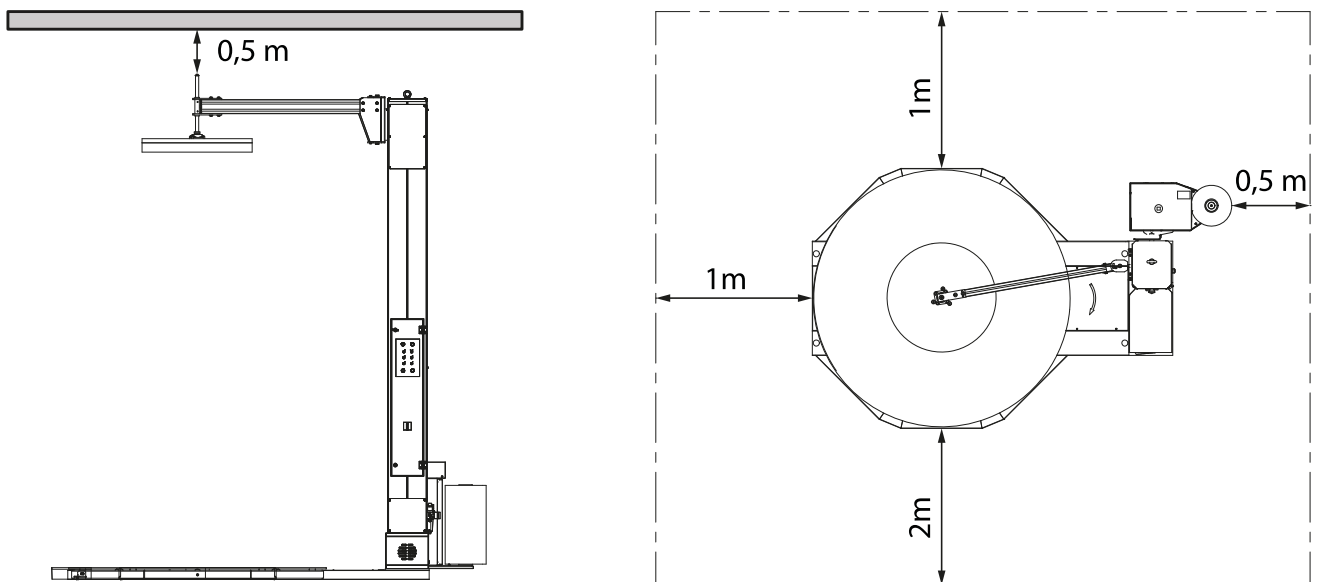

Picture 37

5.3 POSITIONING THE MACHINE

5.3.1 STANDARD MACHINE

In its standard version, the machine is dispatched as follows:

- base column tipped over the turntable;
- presser unit (if supplied) dismantled.

No particular preparation is required for the surface on which the machine is to stand. The surface must be smooth and flat in all directions (maximum slope 1%) and solid enough to support the fully-laden weight of the machine.

Reposition the base column and assemble the parts removed.

» See Picture 38 - pag. 63

REPOSITIONING THE BASE COLUMN

A) Identify the supplied screws for fixing the base column.

DANGER



The lifting of the column should be carried out using a suitable lifting device (1), fixed to the eyebolt on the column.

B) Lift the base column (2).

C) Insert the screws (3) side and secure the base column of the machine (4).

D) Fit the motor guard (5) and secure it with the screws.

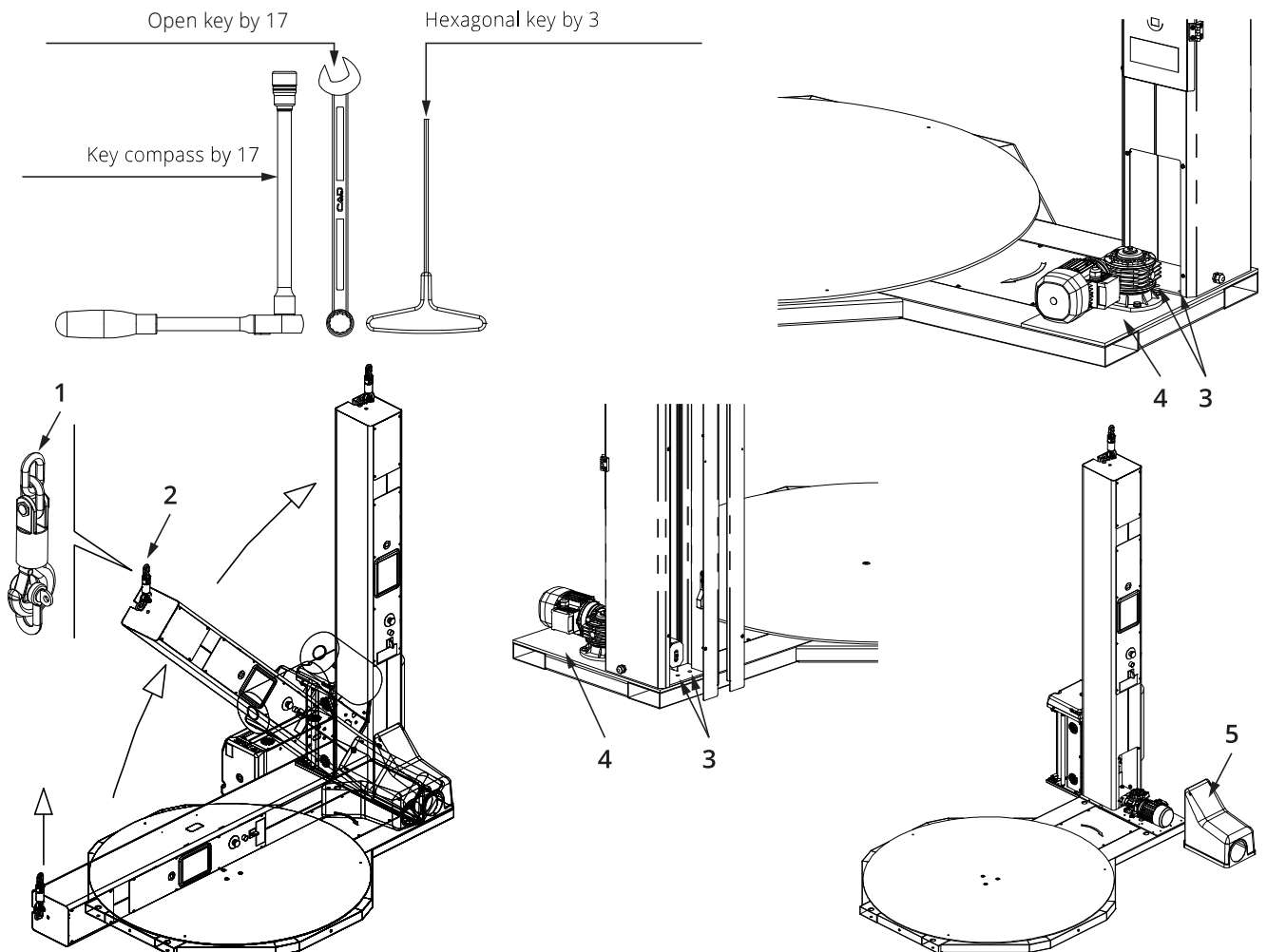

Picture 38

FORKLIFT INSTALLATION

» See Picture 39 - pag. 64

- A) Obtain the screws supplied for fastening the carriage.
- B) Partially tighten the screws **(1)** with the washers **(2)** in the holes/ inserts **(3)** leaving 5-10 mm of space between the washer and the insert.

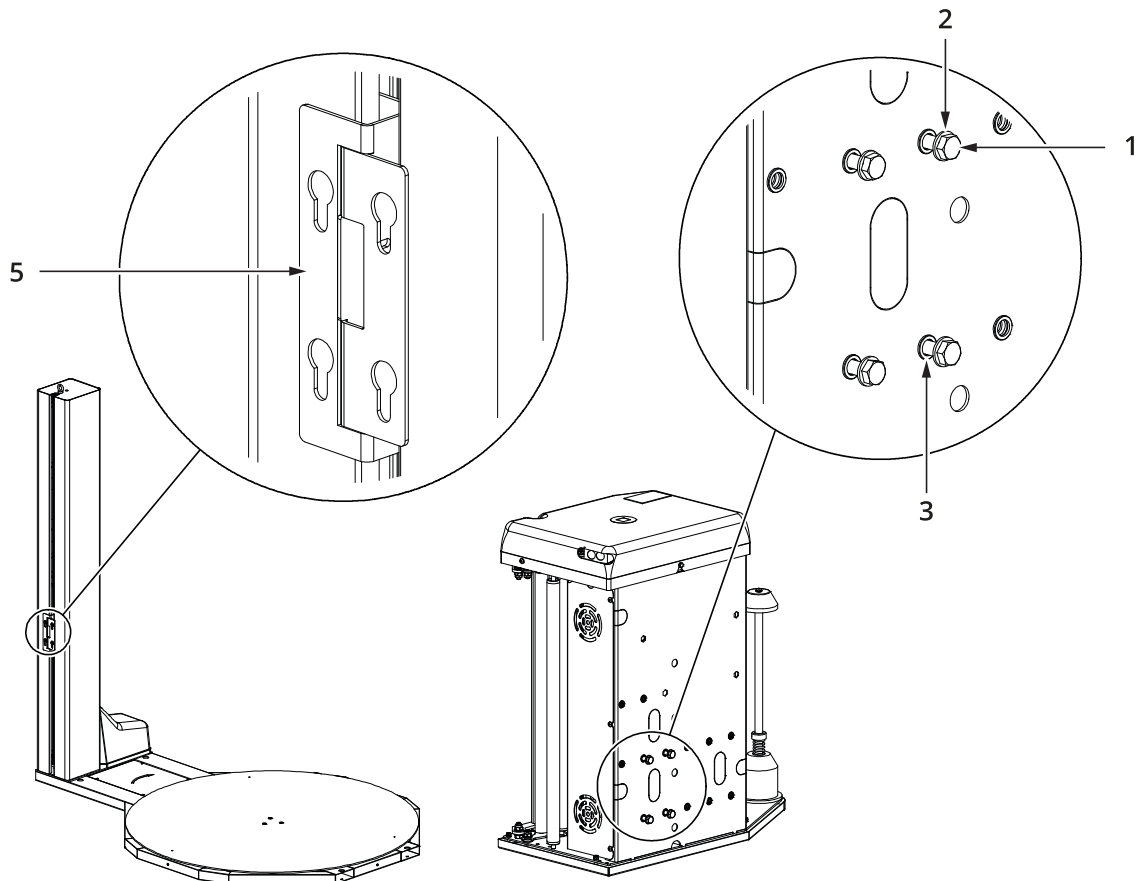

Picture 39

DANGER



Two people are needed to lift the carriage if it weighs over 25 kg.

» See Picture 40 - pag. 65

- C) Lift the carriage (4) and hook it to the support (5), inserting the screws in the shaped holes (6) (figure A).
- D) Lower the carriage to bring the screws to the end of the slot (6) (figure B).
- E) Tighten the screws (1) to fasten the carriage (4) (figure B).

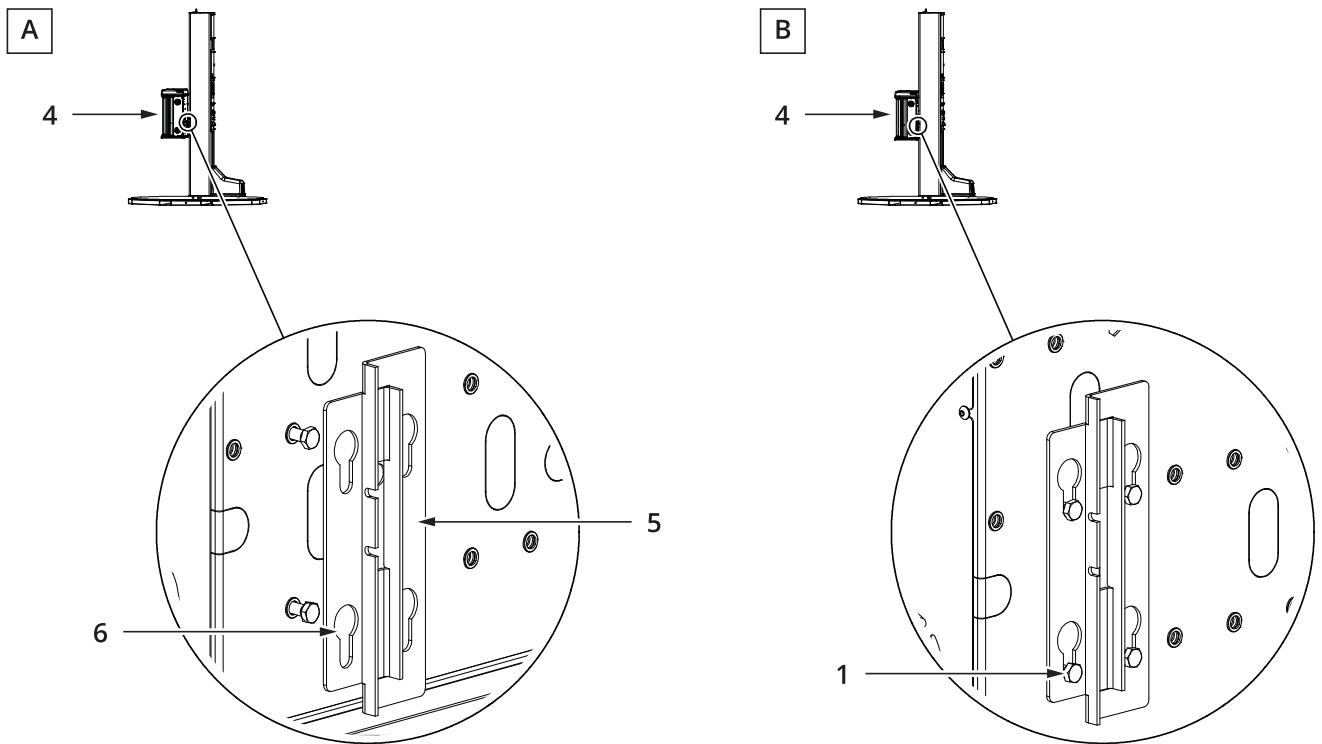

Picture 40

MOUNTING THE PRESSER UNIT (OPTIONAL)

» See Picture 41 - pag. 66

After lifting and fixing the column, mount the pressing arm.

- A) Get the provided screws.
- B) Lift the complete arm **(1)** up to the attachment **(2)**, tighten and secure the screws **(3)**.
- C) Connect the cable **(4)** to the connector **(5)**.

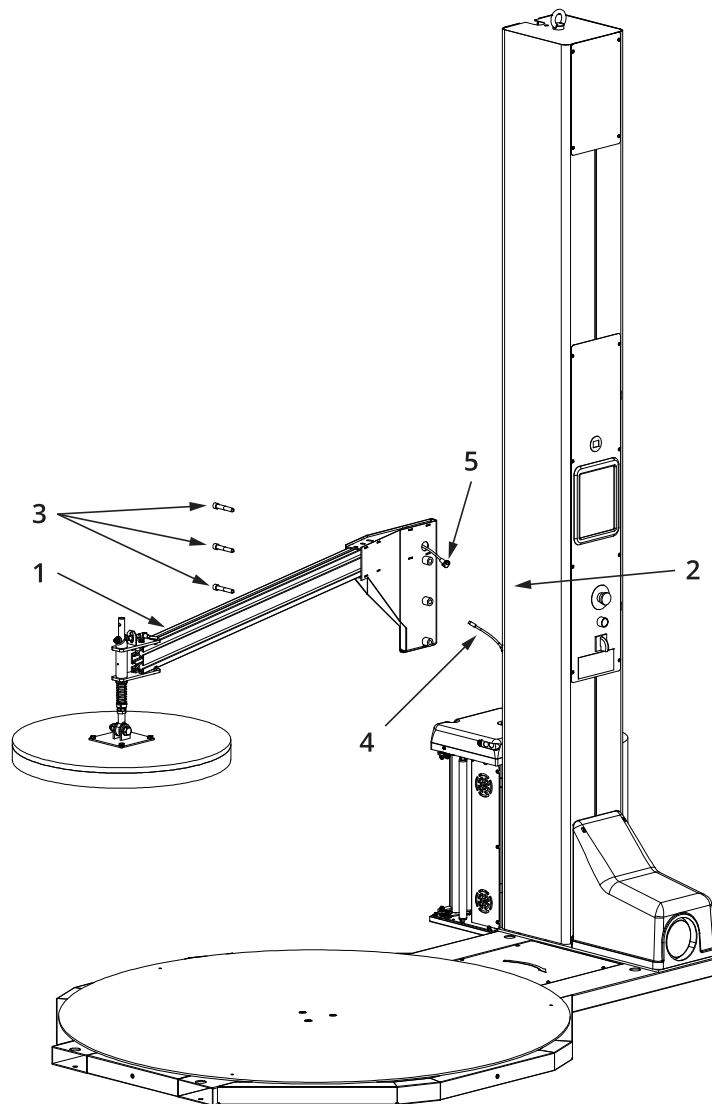

Picture 41

FIXING TO THE FLOOR

» See Picture 42 - pag. 67

- A) Make holes in the floor at point **(1-2-3-4)**, drilling through the holes in the machine base.
- B) Insert steel anchors and tighten.

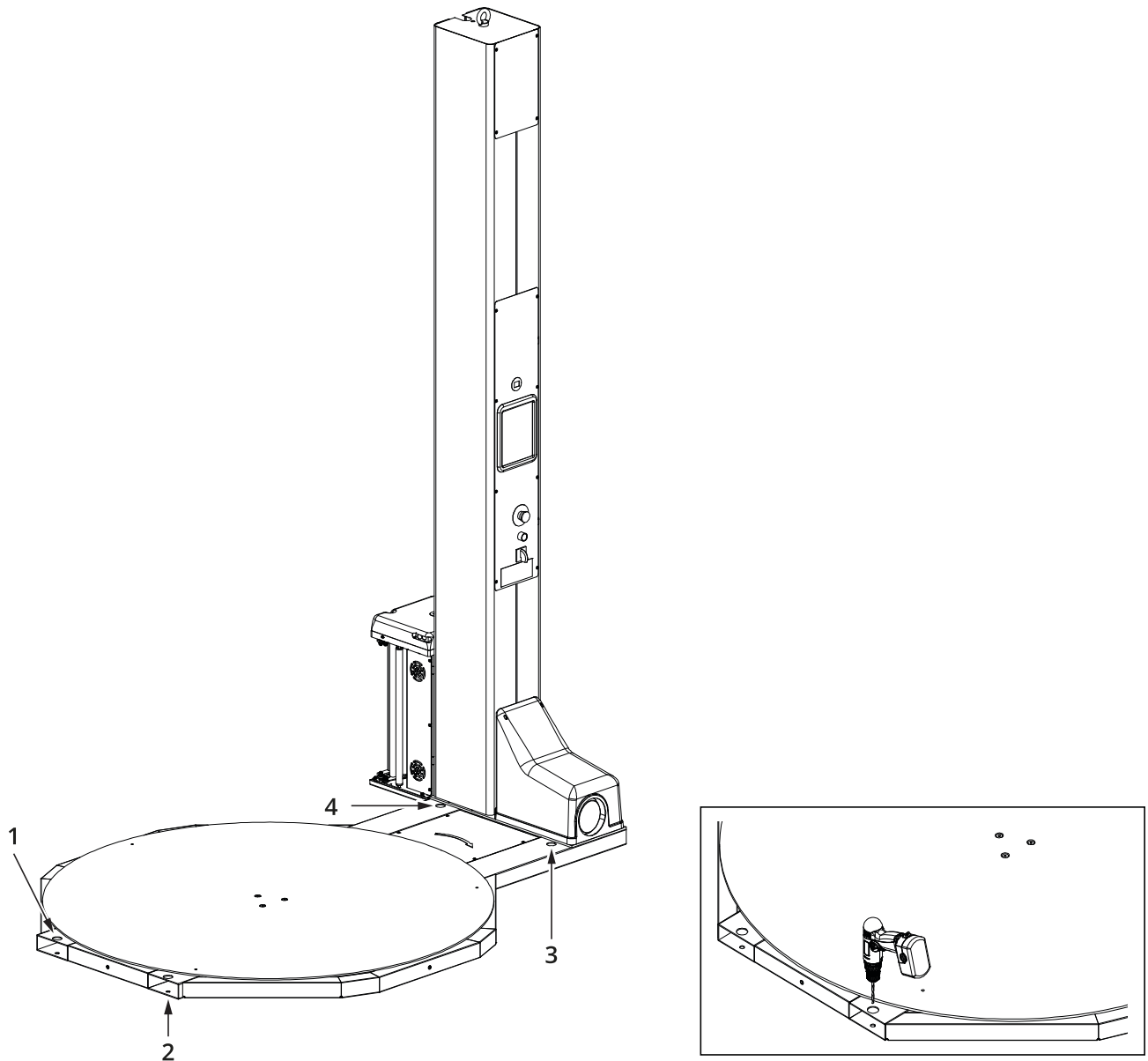

Picture 42

5.3.2 LOW PROFILE MACHINE

ATTACHING THE LOW PROFILE BASE TO THE GROUND

- A) Position the machine in the desired location and remove the supports **(B)** for handling the machine **(A)**.

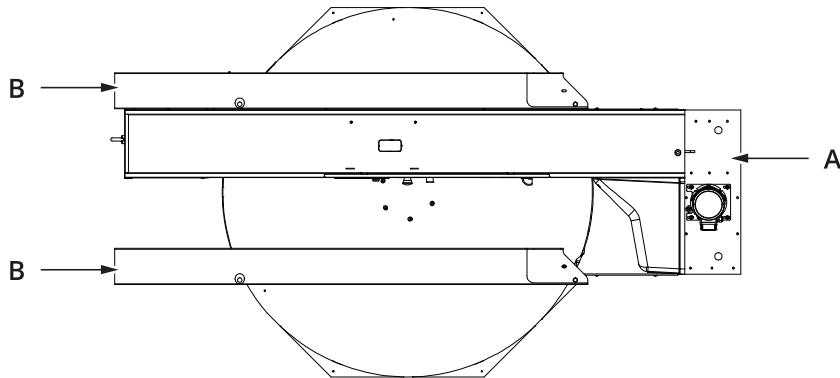

Picture 43

- B) Make holes in the floor at point **(1-2-3-4)**, drilling through the holes in the machine base.
- C) Insert the steel anchors and tighten.
- D) Position the ramp **(5)** in correspondence with the holes and attach it using the screws **(6)**. If there are several ramps, repeat the operation for each one.

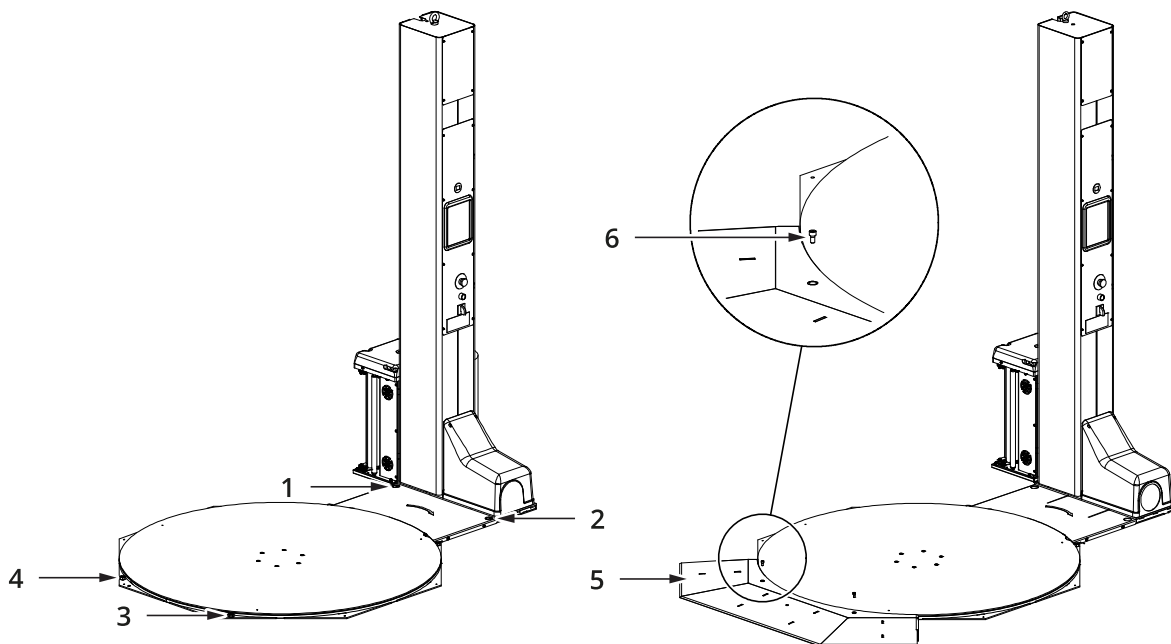

Picture 44

5.3.3 TRANSPALLET MACHINE

» See Picture 45 - pag. 69

FIXING THE TRANSPALLET MACHINE TO THE GROUND

- A) Dismantle the four safety covers (1-2-3-4).
- B) Make the holes in the floor at the points (5-6-7-8-9-10-11-12) drilling through the holes in the machine base.
- C) Insert the steel anchors and tighten.
- D) Assemble the four safety covers (1-2-3-4).

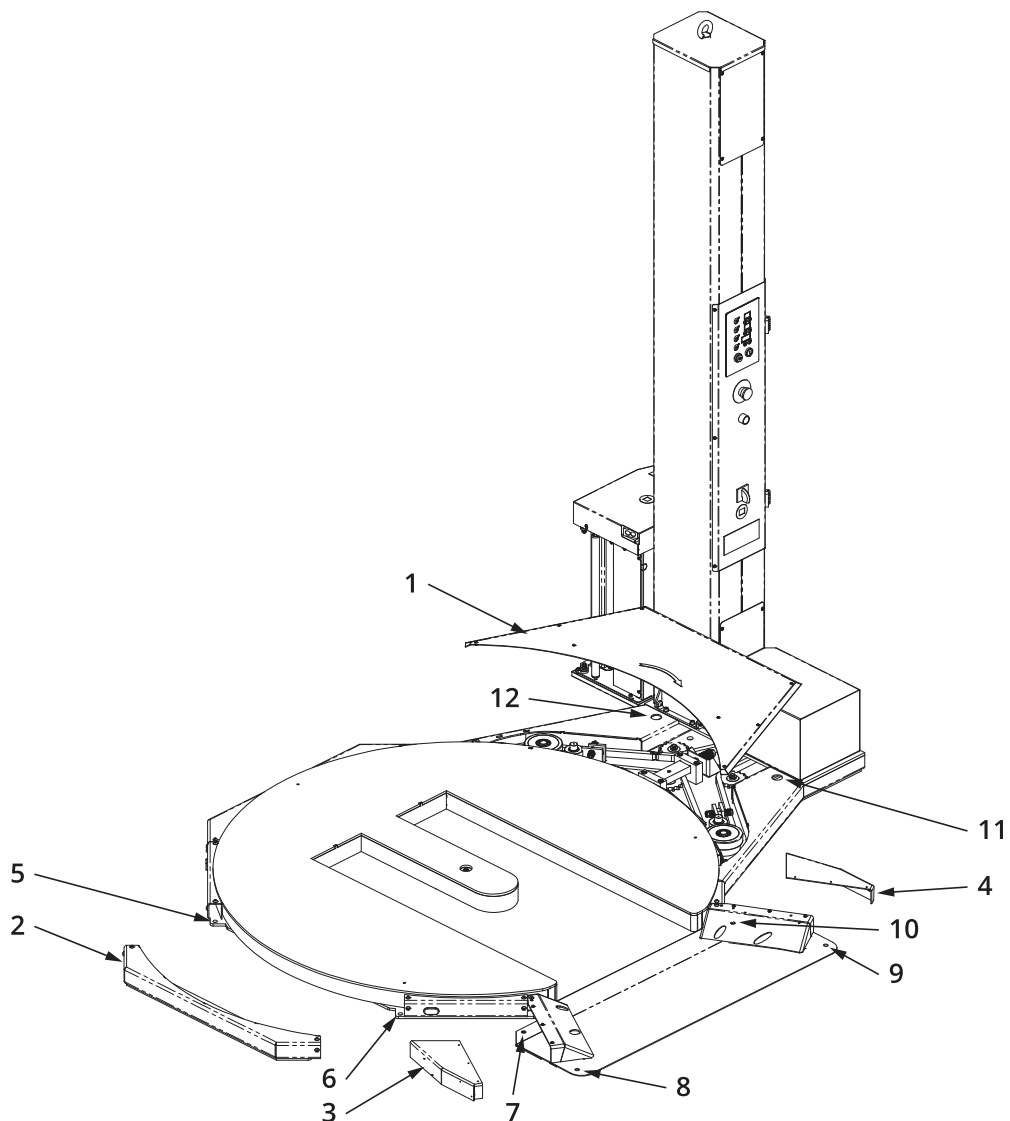

Picture 45

POSITIONING RAMP FOR TP MACHINE ENTRY

» See Picture 46 - pag. 70

The machine may be delivered with the entry ramp already installed or not installed but ready to be installed on the side chosen during the order phase.

To install, proceed as follows:

- A) Remove the casings **(1)** and **(2)**.
- B) Position the ramp **(3)** in the open side of the base **(4)**.
- C) Tighten and lock the screws **(5)**.
- D) Connect the connector **(6)** to the sensor **(7)**.
- E) Replace the casings **(1)** and **(2)**.

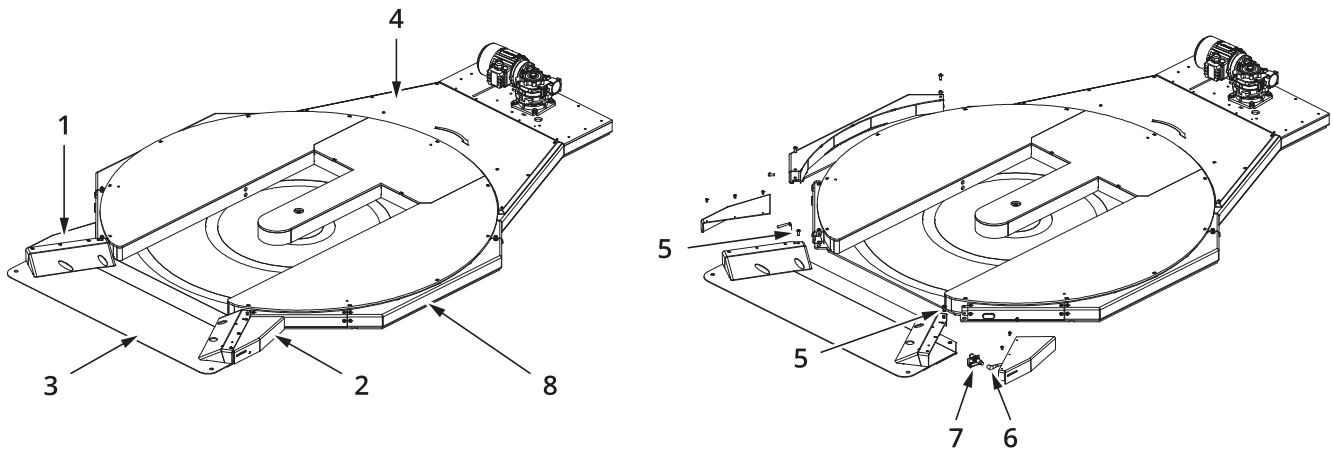

Picture 46

To install the ramp on a different side or to move it, proceed as follows:

» See Picture 47 - pag. 71

- A) Remove the casings (1) and (2).
- B) Disconnect the connector (6) from the sensor (7).
- C) Remove the screws (5) and detach the ramp (3) from the base (4).
- D) Once the side where the ramp (3) is to be installed is determined, remove the casing (8) by removing the screws (9).

INFORMATION



Based on the rotation direction of the plate, the casings (8) contain the connector cable (6). If present, the cable must be removed before the casing, sliding it backward.

- E) Re-install the ramp (3) and the casing (8) in the new positions, tighten and lock the screws (5) and (9).
- F) Using the path provided by the casings (8), run the connector (6) back to the sensor (7) and connect them.
- G) Replace the casings (1) and (2).

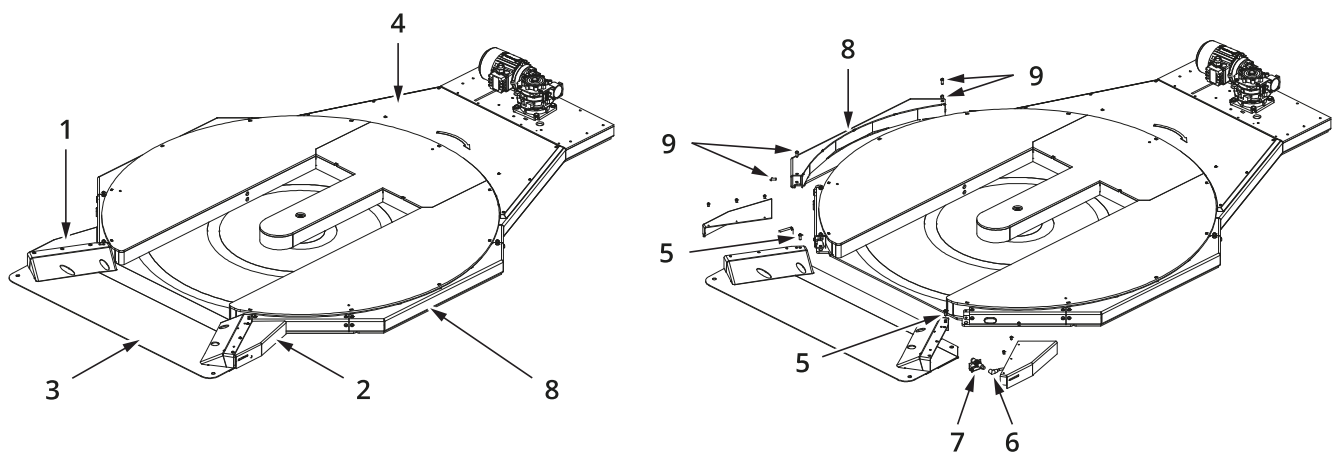

Picture 47

» See Picture 48 - pag. 72

H) Move the reflector **(10)** in the proper position so when the turntable **(11)** opening corresponds to the ramp **(3)**, the reflector **(10)** corresponds to the sensor **(12)** and remains in that position regardless of the position of the ramp **(3)**. To facilitate the operation, manually turn the plate until the reflector **(10)** is in correspondence with the open side, remove it by unscrewing the screws **(13)**, turn the plate again until the open side is located in the new mounting position for the reflector **(10)**, and attach it using the same screws **(13)**.

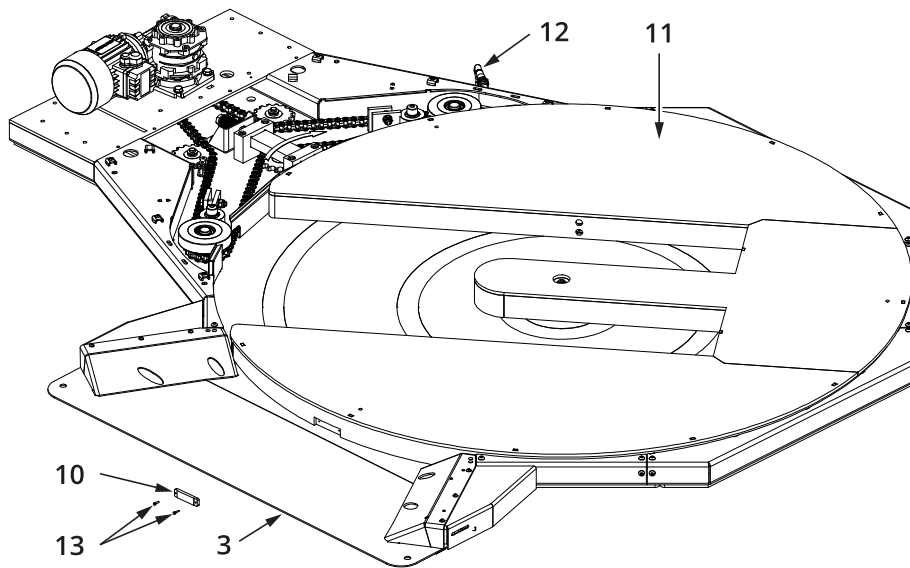

Picture 48

» See Picture 49 - pag. 72

- I - for front position
- II - for right position
- III - for left position

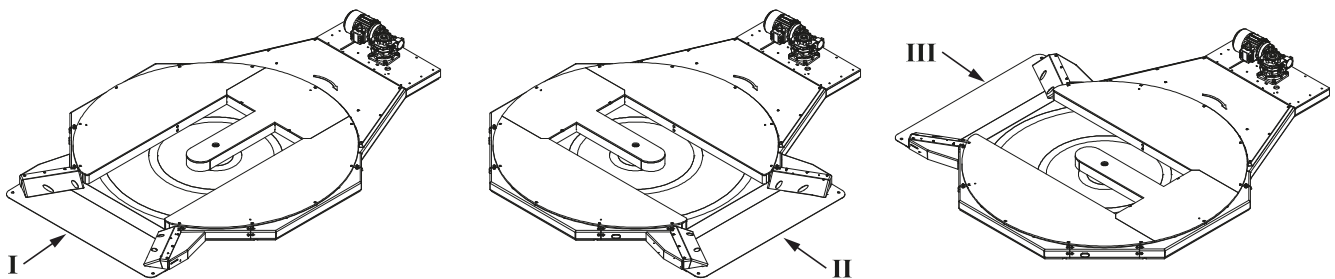

Picture 49

MOUNTING THE RAMPS (OPTIONAL)

» See Picture 50 - pag. 73

The ramp can be mounted on three sides of the base.

To mount the ramp, proceed as follows:

- A) Partially tighten the screw **(1)** in the base and snap the ramp slot from the top to the bottom.
- B) Adjust screw **(3)** to make the ramp flush with the base.
- C) Adjust the distance **(X)** of the ramp from the turntable by tightening or loosening screws **(2)**, **the distance must be adjusted to 2 ÷ 5 mm (max)**.
- D) Tighten the screw **(1)**.
- E) Tighten the lock nuts.

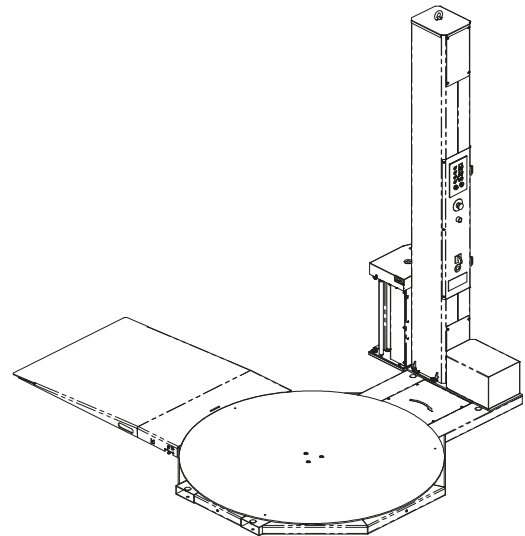
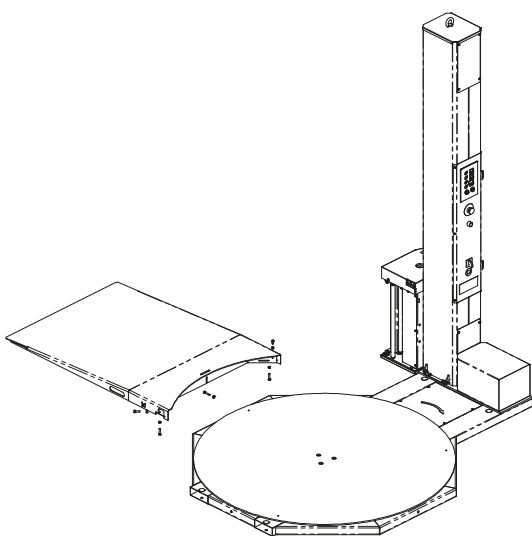
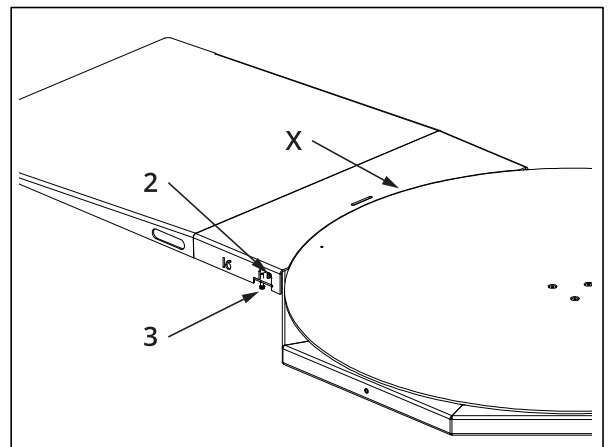
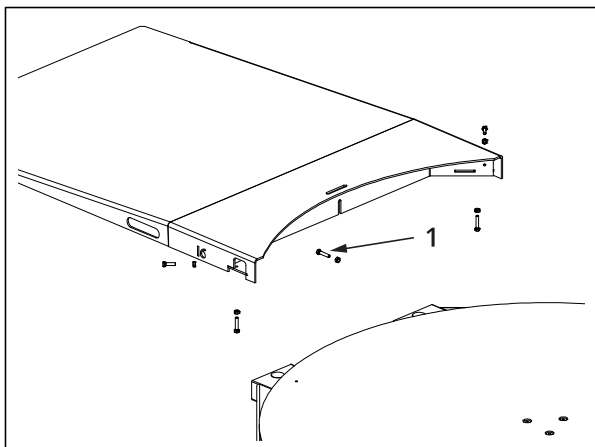

Picture 50

5.3.4 MACHINERECESSEDINTOTHEFLOOR(WITHFRAME)

» See Picture 51 - pag. 74

Before assembling the machine, create the recessed area following the diagram representing the reference hole (A).

Make a hole at least 8 cm deep (see A).

Embed the template flush with the floor (B), level the bottom of the hole and fill in any unused areas (B1) as stated in the template's technical specifications.

If present, remove the cross-pipes (B2), Insert the machine (C1) and fix the sections (C2) around the plate, centring them and securing them with the screws (C3) in the free space between the round plate and the walled frame, **the distance between the turntable and sections must be adjusted to 2 ÷ 5 mm (max).**

The completed assembly is shown in (D).

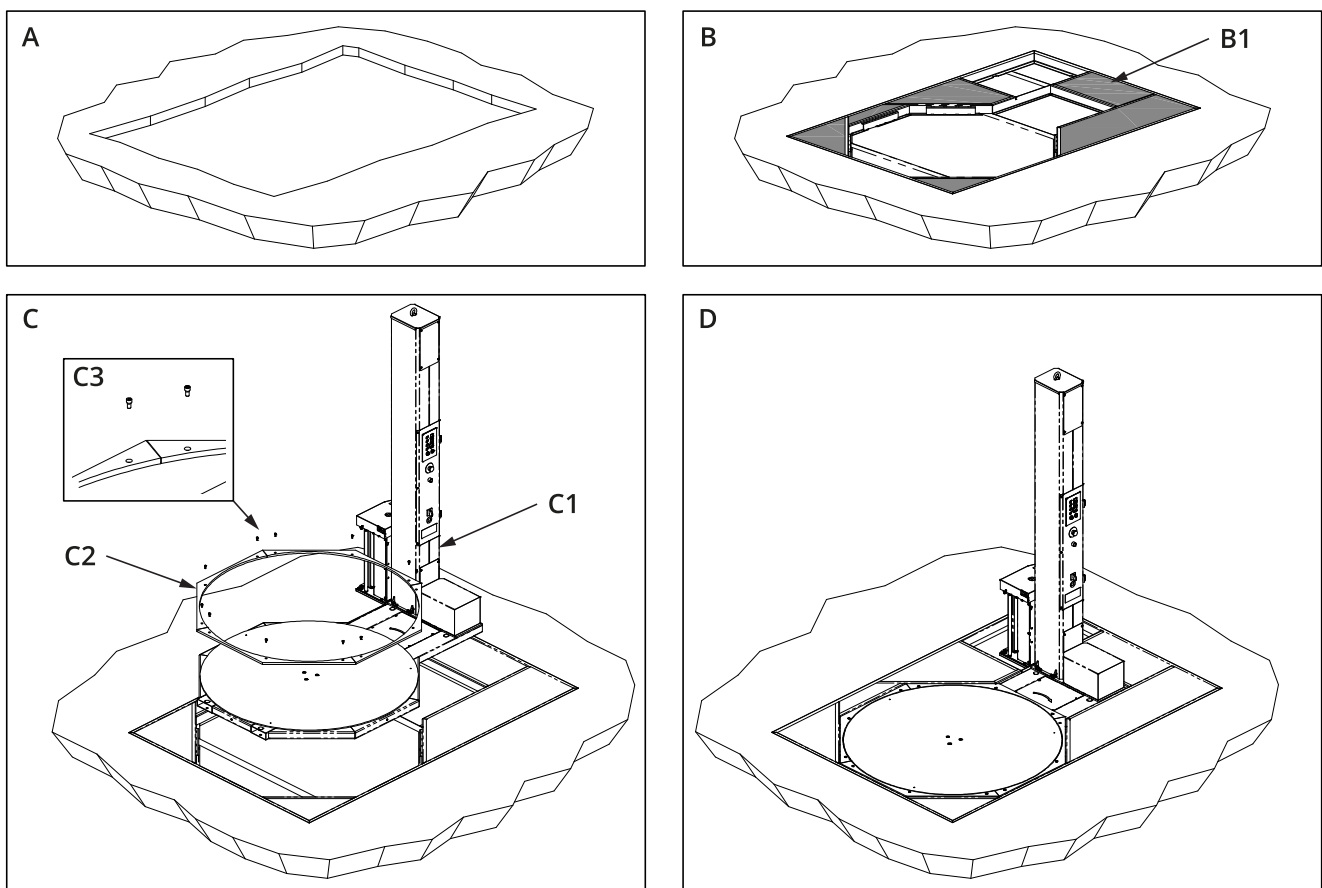

Picture 51

5.3.5 MACHINE RECESSED INTO THE FLOOR (WITHOUT FRAME)

» See Picture 52 - pag. 75

Before assembling the machine, create the recessed area following the diagram representing the reference hole **(A)**.

Position the machine **(1)** inside the hole (see **B**) and centre it, distributing the space in equal measure between the sides (25 mm) (see **C**).

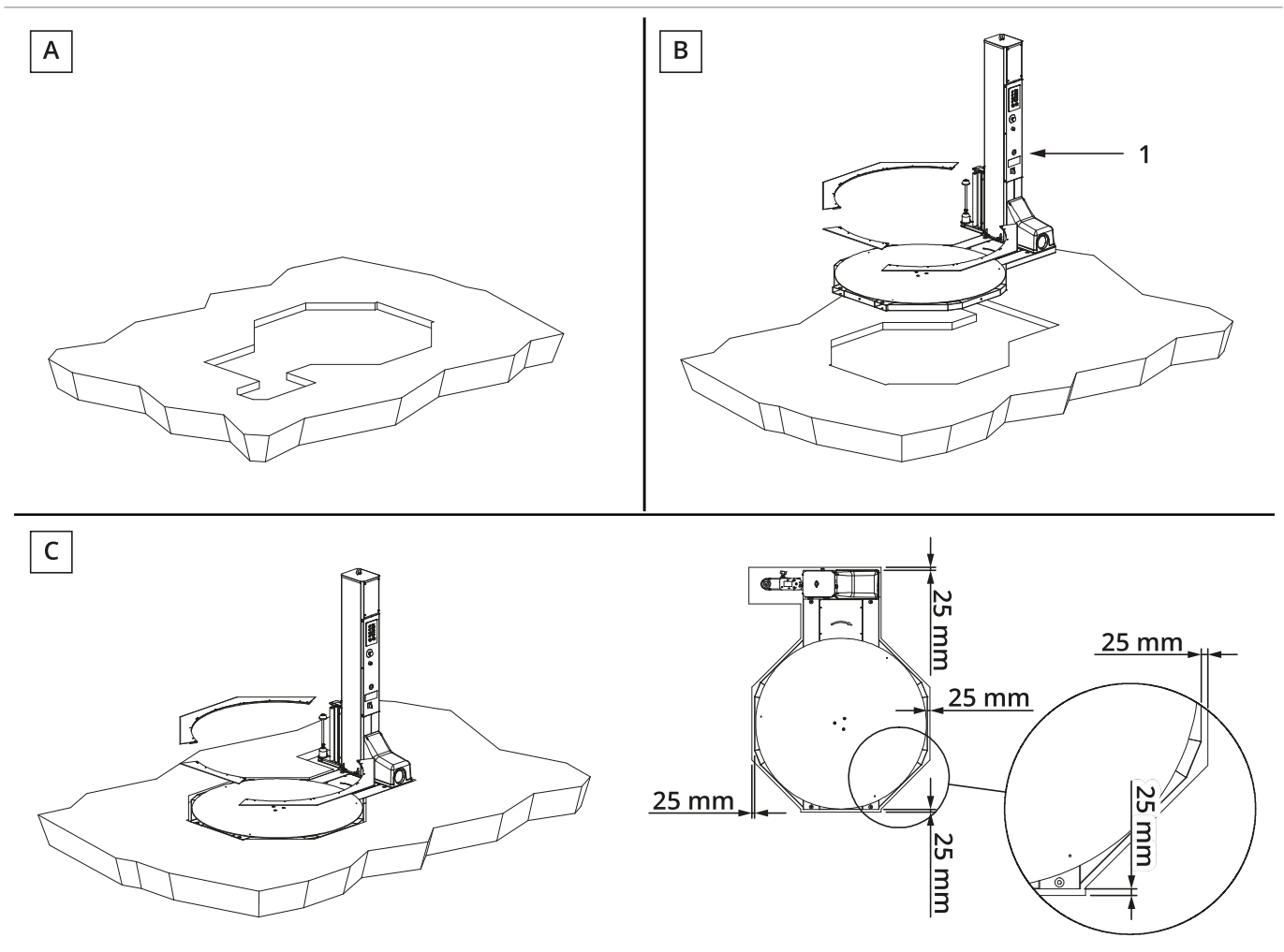

Picture 52

Check the proper position of the machine, resting the sections **(2)** and **(3)** around the plate **(4)** leaving a distance of ~5 mm from the plate itself.

If needed, correct the position of the machine **(1)** inside the hole to properly position the sections **(2)** and **(3)**.

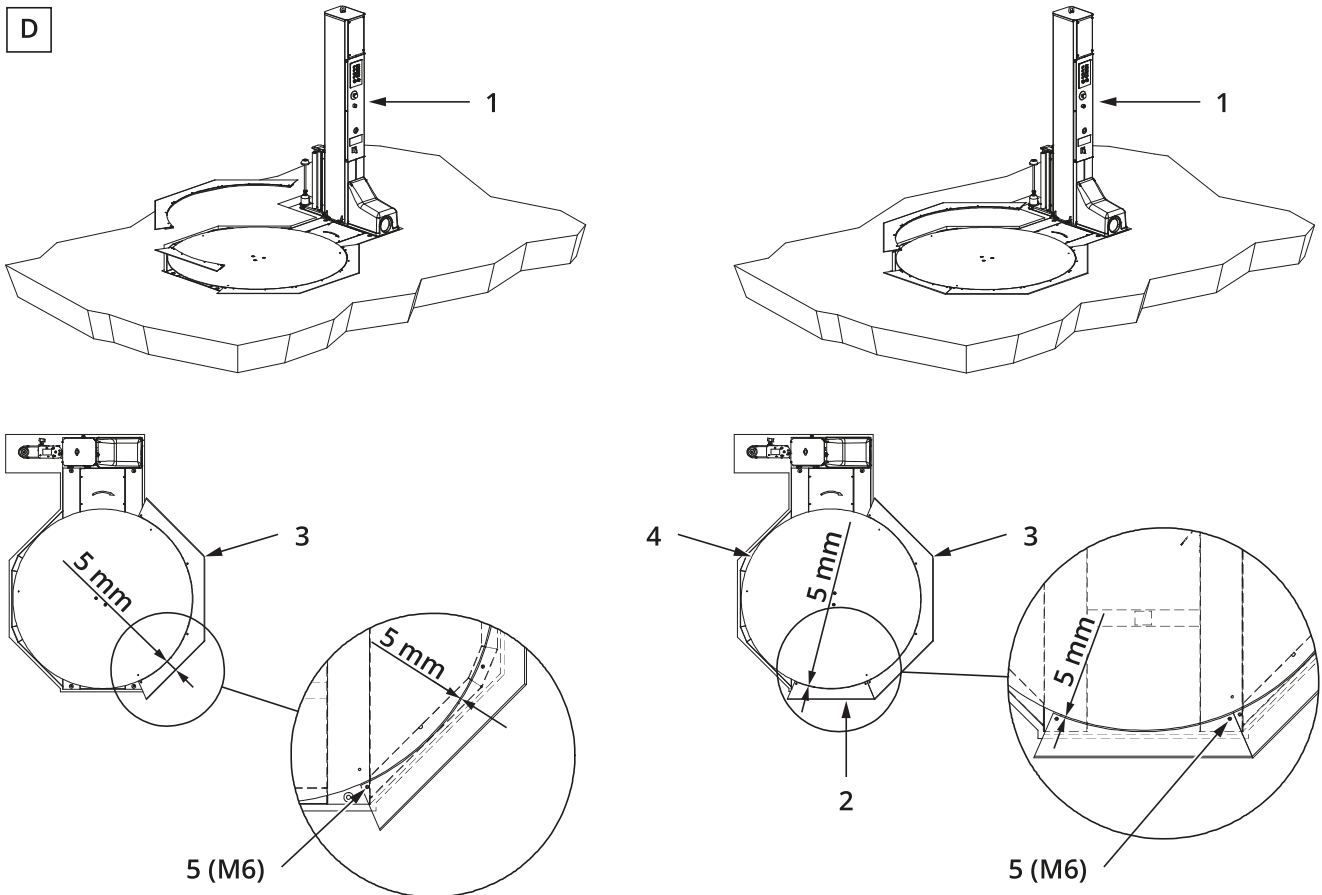

Picture 53

Remove the sections and attach the machine to the ground using the holes.

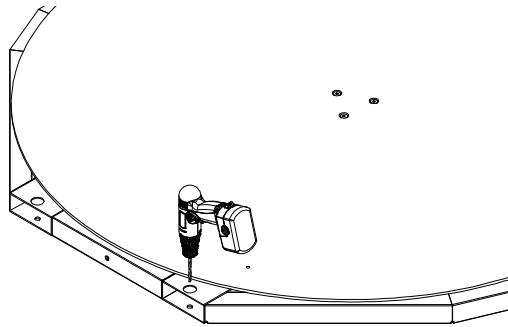

Picture 54

Replace the sections **(2)** and **(3)**, positioning them according to the previous instructions, 5 mm from the turntable; drill and M6 thread the base in correspondence of the holes **(5)** and attach the sections with a HSHC M6 screw. **(D)**

Check for proper mounting **(E)**.

E

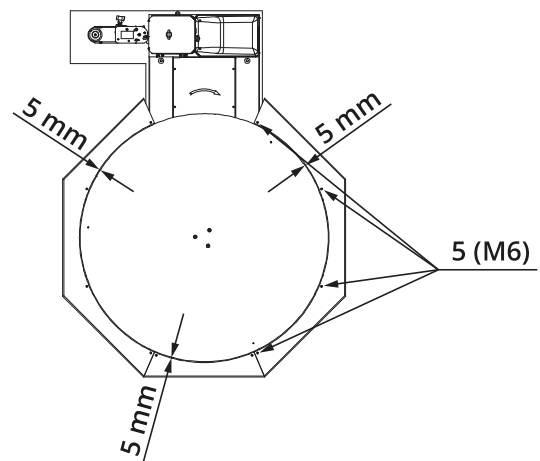
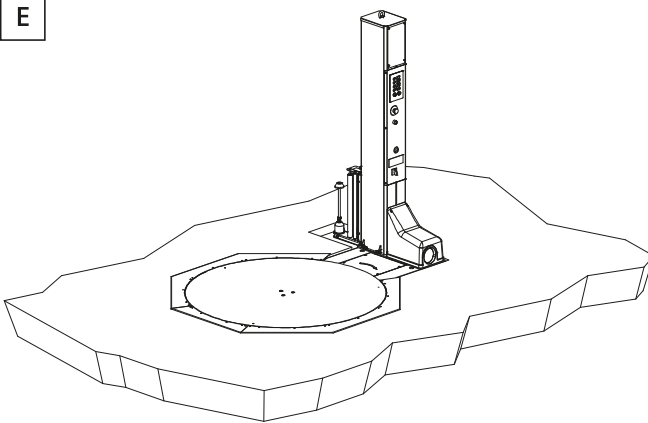

Picture 55

5.3.6 MACHINE WITH WEIGHING BASE

Position the machine in the intended location; position the plates (A and B) as in the drawing so that the feet (C) fit in the specific seats (D).

Level the machine by adjusting the height of each foot (C) until the work surface is perfectly horizontal.

WARNING



USE OF A SPIRIT LEVEL IS RECOMMENDED TO CORRECTLY LEVEL THE MACHINE.

ADJUST THE FEET SO THE WEIGHT IS DISTRIBUTED EQUALLY ON THEM. THE ACCURACY OF THIS OPERATION PREVENTS VIBRATIONS OR NOISES AND ENSURES GREATER RIGIDITY OF THE MACHINE AND ACCURATE WEIGHING.

Drill holes in the floor, at points (1-2-3-4-5-6), passing through the holes in the plates (A and B).

Insert the steel anchors and tighten.

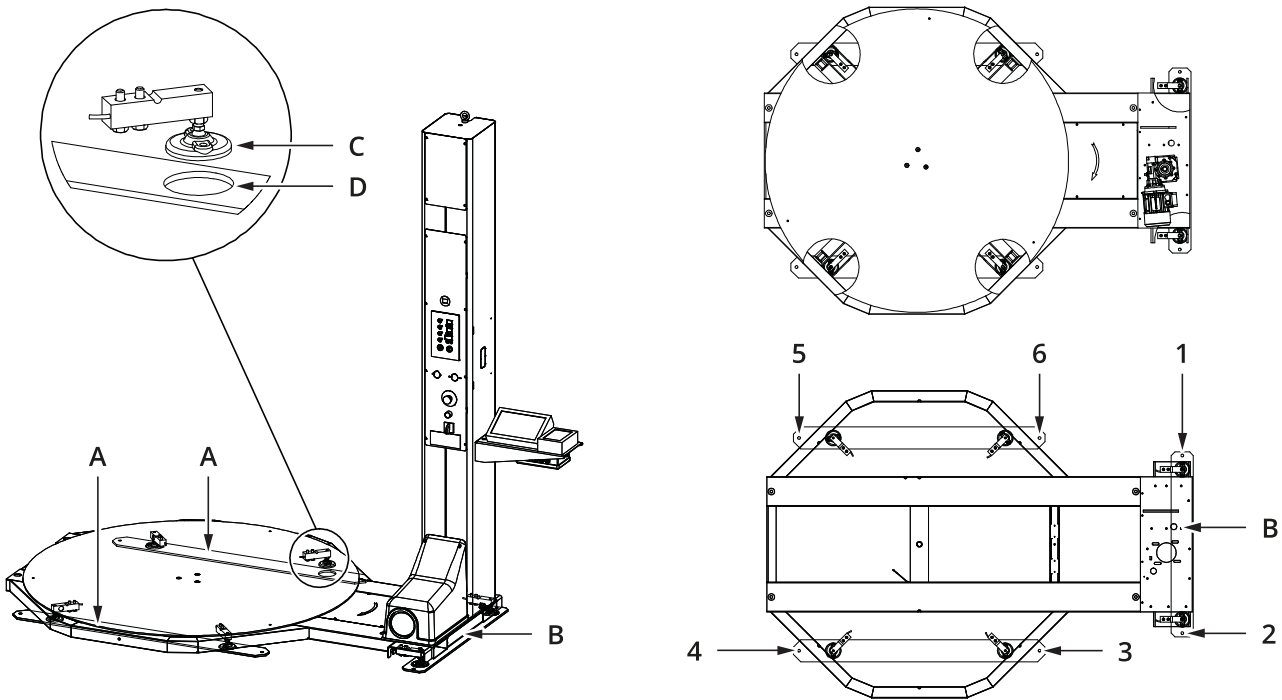

Picture 56

5.3.7 MACHINE WITH TRANSPALLET AND WEIGHING BASE

The turntable (1) on this machine is made up of a plate and a counter-plate with the following inside:

- loading cells (2)
- transmitter to the scale (3)
- batteries (4)
- switch to turn on the module (5)
- battery charger port (6)

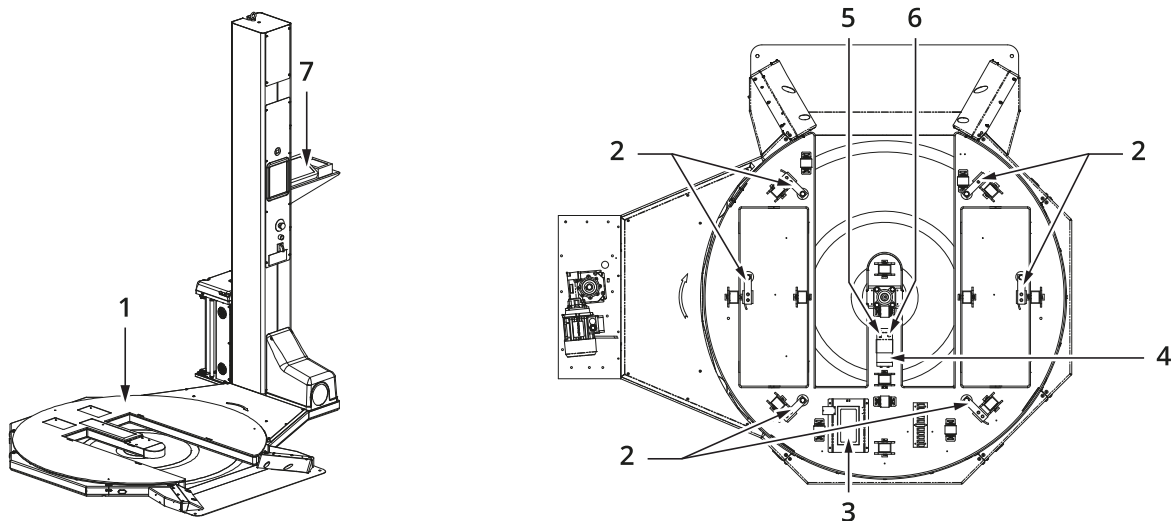

Picture 57

The unit also has a display panel (7) with optional printer mounted on the machine column and powered by the machine itself.

Before using the scale for the first time, completely charge the battery (4) for at least 10 hours, using the supplied battery charger.

Plug the charger into the port (6) next to the on button (5) then plug it into the power.

INFORMATION



During normal use, this operation must be repeated every evening at the end of the work shift to prolong battery life.

DANGER



Do not wrap products while the batteries are charging.

5.4 ELECTRICAL CONNECTION

The machine is supplied with a cable **(1)** without a plug and already connected to the terminal board on the electric panel.

DANGER



THE ELECTRICIAN MUST CORRECTLY FIT AN APPROPRIATE PLUG ACCORDING TO THE CURRENT REGULATIONS IN THE COUNTRY OF USE.

DANGER



THE ELECTRICAL POWER SYSTEM CONNECTED TO THIS PRODUCT MUST BE SET UP IN CONFORMITY WITH THE SAFETY STANDARDS CURRENTLY IN FORCE, EQUIPPED WITH A DIFFERENTIAL SWITCH AND AN EARTH CIRCUIT. THE VOLTAGE AND FREQUENCY MUST BE COMPATIBLE WITH THE REQUISITES GIVEN ON THE IDENTIFICATION PLATE. The differential must be type B or F and a maximum of 300 mA for purely industrial applications and 30 mA for civil or mixed applications.

The plug must be wired as shown in the following colour scheme:

Brown: Phase - Blue: Neutral - Yellow-green: Earth

Turn the main power switch **(2)** to 'I'-ON.

DANGER



ANY FAULTS OR ANOMALIES IN THE EARTH CIRCUIT CONNECTED TO THE MACHINE CAN, IN THE EVENT OF BREAKDOWN, LEAD TO THE OPERATOR SUFFERING ELECTRIC SHOCK WITH THE CONSEQUENT RISK OF DEATH OR SERIOUS INJURY TO THEIR HEALTH.

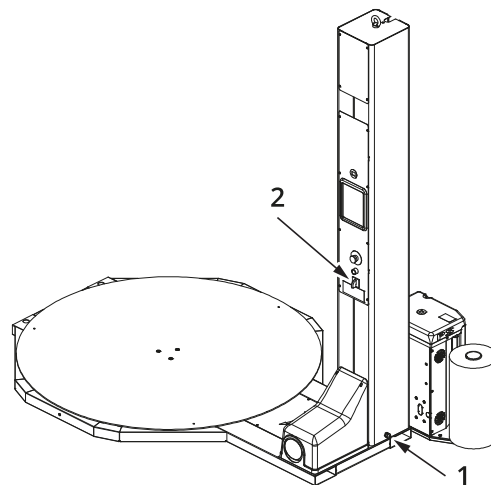

Picture 58

6 STARTING UP THE MACHINE

6.1 ELECTRICAL PANEL

1) Main switch

Switches the machine on and off, cutting off the mains power supply.

2) Reset button

Provides power to the auxiliary circuits, has to be pressed after switching on or after the emergency button has been pressed.

3) Emergency button

Stop the machine and cuts off the main power supply in situations of emergency or imminent danger; to reset the button once it has been pressed, turn the top of the button clockwise.

4) Control panel

Used to control the machine and the work cycle (for more information, consult the attached Operator Panel manual).

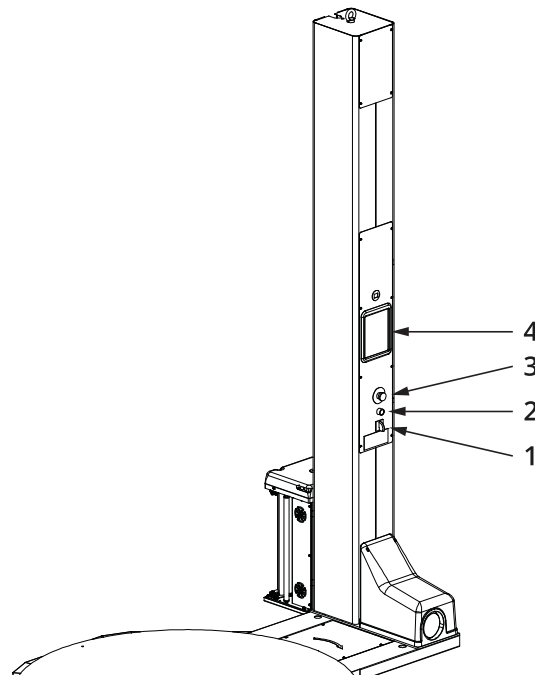

Picture 59

6.2 INSTRUCTIONS FOR USE

6.2.1 LOADING A ROLL OF FILM

» See Picture 60 - pag. 83

This is a general procedure.

Carriage-specific operations are described in the relative roll-holder carriage manual.

- A) Lower the roll-holder carriage **(1)** to make it easier to load the roll;
- B) turn the main switch **(2)** to 'O'-OFF;
- C) open the carriage door (depending on the carriage model);
- D) push the roll **(3)** onto the carriage pin **(4)**;
- E) unwrap the film and thread it between the rollers;
- F) close the carriage door.

6.2.2 STARTING THE MACHINE

» See Picture 60 - pag. 83

- I) Correctly place the pallet on the turntable **(5)**;
- J) check that there is a roll of film **(3)** on the roll-holder shaft **(4)** and check that the film is correctly routed according to the diagram (see plate **(6)** indicated for the carriage **(1)** being used;
- K) turn ON the panel using the main switch **(2)** and press the reset button **(7)** to enable the machine;
- L) manually draw out the film protruding from the roll-holder carriage **(1)** and attach it to a corner of the pallet;
- M) set the operating cycle from the control panel
- N) press the START button **(A)** on the operator terminal;
- O) After wrapping, manually cut the film and fix it to the pallet;
- P) the pallet can now be unloaded.

6.2.3 CYCLE STOP

Press STOP **(0)** on the operator terminal to stop machine at the end of its current cycle.

6.2.4 STOPPING THE MACHINE AFTER USE

» See Picture 60 - pag. 83

After using the machine, even for short periods of inactivity, it must be put into the safe mode.

- A) Lower the turntable down to the ground **(1)**.
- B) Switch off the machine by turning the main power switch **(2)** to 'O'-OFF position.
- C) Remove the pallet from the turntable **(5)**.

6.2.5 EMERGENCY STOP

» See Picture 60 - pag. 83

The machine is equipped with an emergency pushbutton **(8)**. Pressing the pushbutton, the machine will stop immediately. To restart the machine it is necessary to turn the pushbutton to rearm and press the button to reactivate the control panel.

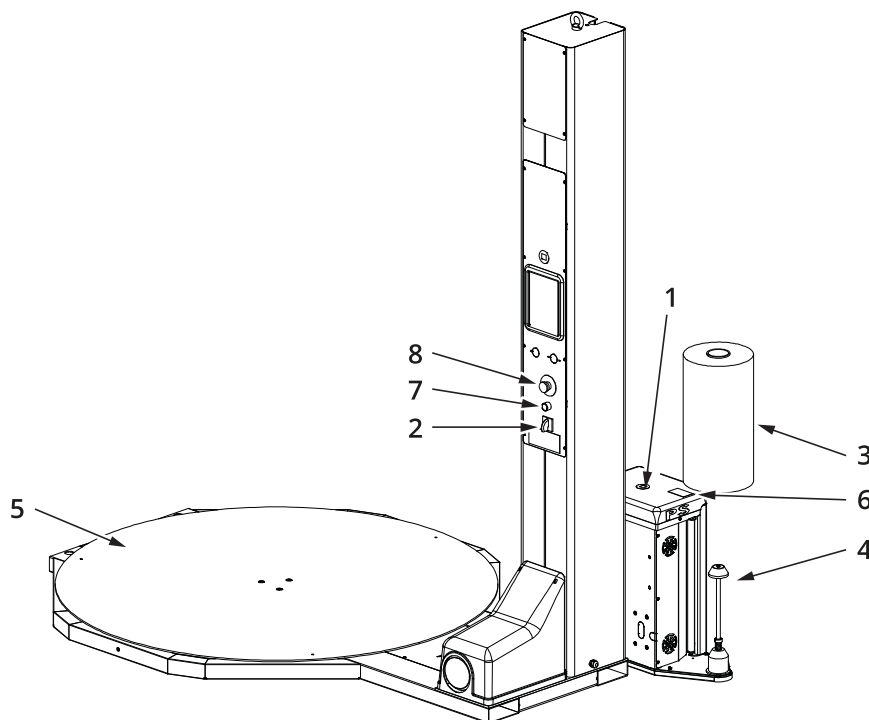

Picture 60

6.2.6 SAFETY SYSTEMS EFFICIENCY CHECK

This section contains a description of the actions the operator must take to test the efficiency of the safety systems, before starting up production.

DANGER



THIS PROCEDURE CAN BE OPERATED ONLY BY A GRADE 2 QUALIFIED MAINTENANCE ENGINEER.

6.2.7 EMERGENCY BUTTONS OPERATIONAL CHECK

» See Picture 61 - pag. 84

With the machine running, press the emergency pushbutton **(A)**. Check that the machine comes to an immediate halt. Release the previously pressed emergency pushbutton and press the ENABLE MACHINE pushbutton. Press START to restart the machine.

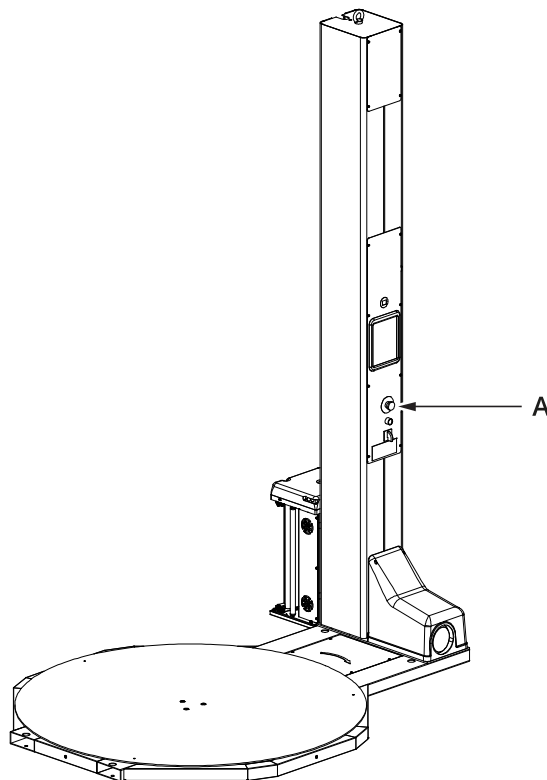

Picture 61

7 MAINTENANCE

7.1 GENERAL PRECAUTIONS

DANGER



Maintenance personnel must act in accordance with the instructions contained in this document and strictly observing the accident prevention regulations set forth by international directives and by the legislation of the country where the machine will be installed.

Additionally, PPE suitable for all maintenance operations must be worn.

WARNING



Maintenance operations that require acting on mechanical parts and/or electrical components must be carried out by qualified technicians.

The operator can only clean and visually check the instruments of the machine.

INFORMATION



All maintenance information refers exclusively to routine maintenance procedures and to works aimed at ensuring that the machine operates correctly on a daily basis. Supplementary maintenance procedures must be carried out by the Manufacturer's specialised technicians.

- Provide sufficient lighting when servicing the machine. If maintenance involves areas that are poorly illuminated, portable lighting devices must be used. Make sure to avoid causing dark cones that prevent or reduce the visibility of the point on which you are going to work or of the surrounding areas.
- Use only original materials when repairing the machine in order to ensure the safety of the machine in any case. The tools available must be suitable for the task to be done. Never use any tool or equipment for a purpose other than that for which they were made.

7.1.1 SPECIAL PRECAUTIONS

When performing maintenance or repair operations, observe the following:

- Before starting work, post a sign "MACHINE UNDER MAINTENANCE" in a well visible position.
- Do not use solvents or flammable materials.
- Take care not to pollute the environment with cooling lubricants.
- Use suitable equipment to access the upper parts of the machine.
- Do not climb onto machine components or guards, as they have not been designed to support the weight of a person.
- After completing the maintenance operations, refit and properly secure all the protection devices and safety guards that have been removed or opened.

7.1.2 CLEANING

Periodically clean the safety guards, particularly the transparent material of the casing, using a damp cloth.

7.2 SCHEDULED MAINTENANCE

This paragraph describes the operations to be carried out periodically in order to ensure proper functioning of the machine.

WARNING



IT IS ESSENTIAL TO SCRUPULOUSLY OBSERVE THE MAINTENANCE OPERATIONS DESCRIBED BELOW IN ORDER TO MAKE THE MACHINE MORE EFFICIENT AND ENSURE A LONGER LIFE.

INFORMATION



IF MACHINE MAINTENANCE IS NOT CARRIED OUT IN COMPLIANCE WITH THE INSTRUCTIONS PROVIDED, THE MANUFACTURER IS RELIEVED OF ALL RESPONSIBILITY FOR MALFUNCTIONING OF THE MACHINE.

7.2.1 ACTIVE SAFETY DEVICES MAINTENANCE

DANGER



CHECK THE EFFICIENCY OF THE SAFETY DEVICES BEFORE STARTING WORK.

» See Picture 62 - pag. 87

DAILY OPERATIONS:

Clean out the crush-protection safety devices with a jet of dry air.

Check that the carriage bottom plate **(A)** are working properly. Make sure also that there are no foreign bodies in the crevices **(C)**.

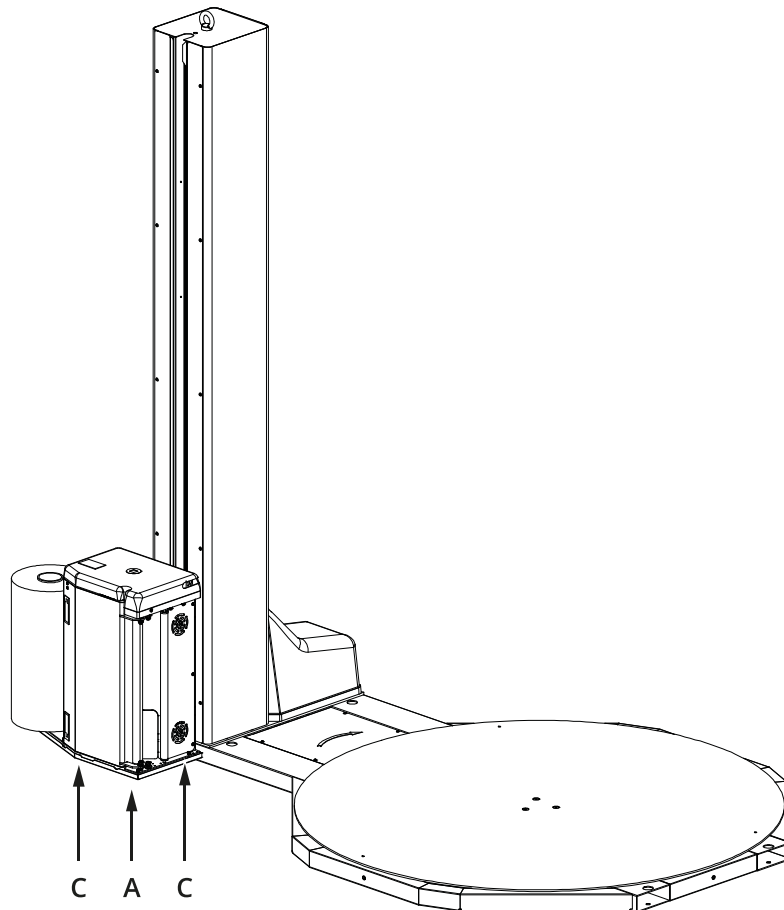

Picture 62

7.2.2 DAILY MAINTENANCE

Cleaning. Carefully eliminate all traces of dirt on all the machine surfaces. Use a clean damp cloth.

Clean the photocells with a clean soft cloth.

7.2.3 QUARTERLY MAINTENANCE

» See Picture 63 - pag. 88

Check the tension of the chain driving the turntable as follows:

Standard turntable

- A) Unscrew the screws **(1)**;
- B) remove the guard **(2)** and **(3)**;
- C) check the tension of the chain **(4)**. To tighten, loosen the screws **(5)**, tighten the screw **(6)** until the tension and tighten the screws **(5)**. Grease the chain;
- D) put back the guard **(2)** and **(3)** and secure it with the screws **(1)**.

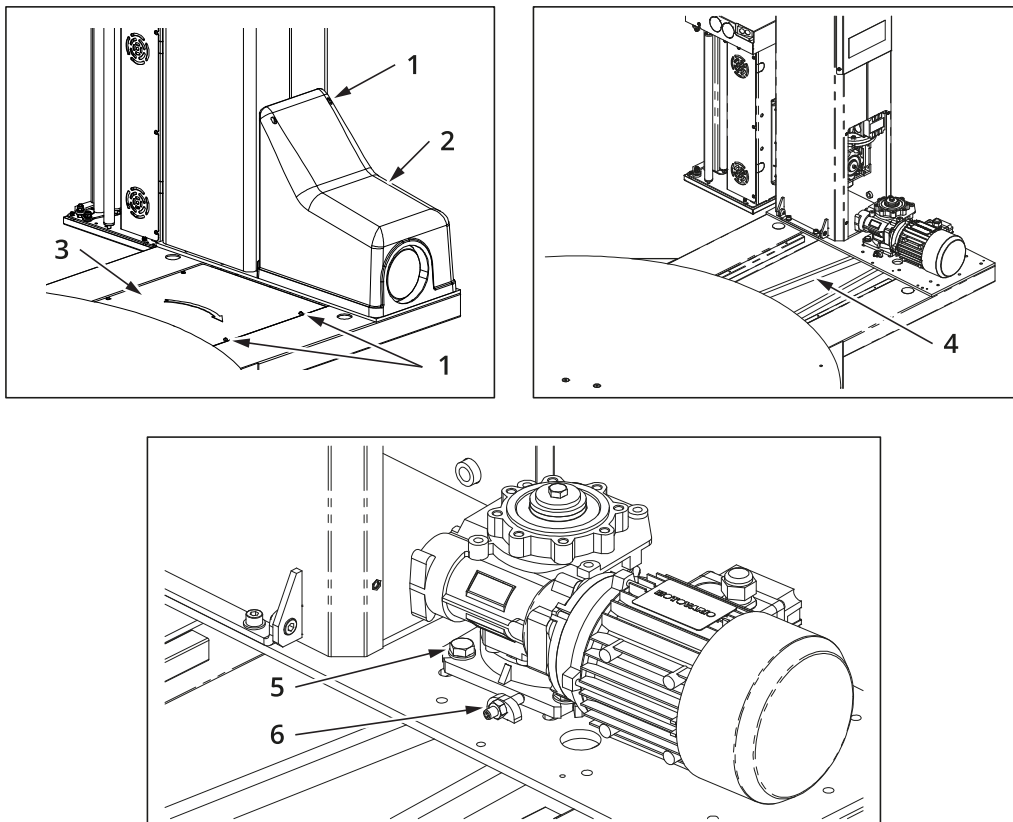

Picture 63

» See Picture 64 - pag. 89

Turntable with transpallet compartment

- A) Unscrew the screws **(1)**;
- B) remove the guard **(2)**;
- C) grease the chain **(3)** and check the tension.
To adjust the chain tension **(3)** proceed as follows:
- D) Loosen the lock nut **(4)**;
- E) loosen the preload screw **(5)** of the springs **(6)** until they are fully released;
- F) tighten the screw **(5)** until the spring is compressed for about 15 mm;
- G) tighten the nut **(4)**.
If adjustment of the screw **(5)** is not sufficient to tighten the chain:
- H) loosen the nut **(4)**;
- I) loosen the screw **(5)**;
- J) loosen the four screws **(7)**;
- K) slide the support **(8)** towards the machine column;
- L) tighten the screws **(7)** and retension the chain as described in points f) and g);
- M) refit the guard **(2)** and secure it with the screws **(1)**.

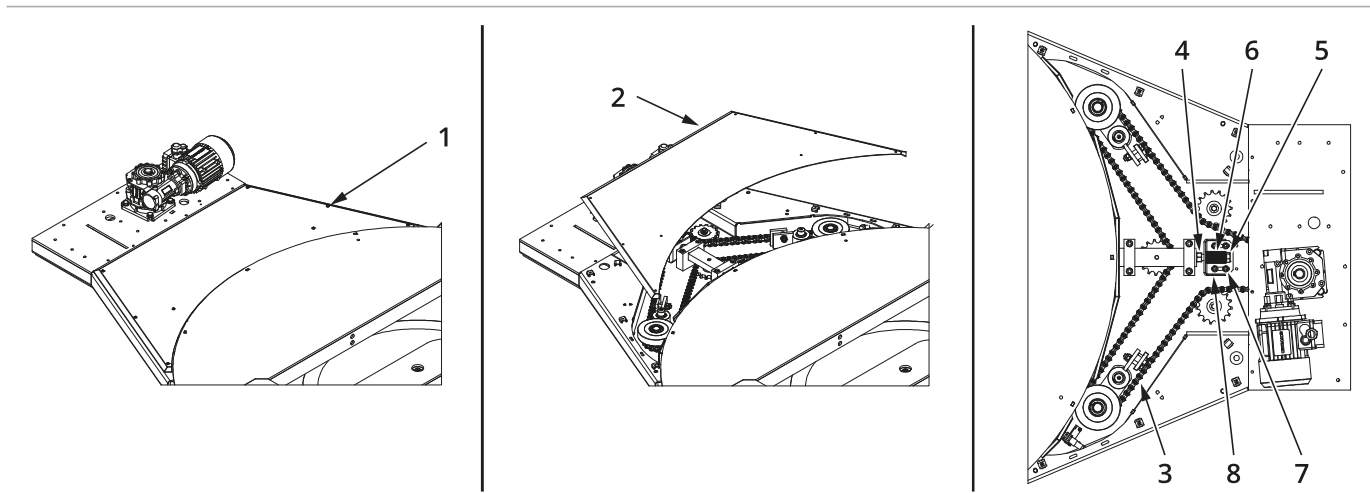

Picture 64

» See Picture 65 - pag. 90

Adjusting the friction wheels

To check and adjust the preload of the friction (driving) wheels **(5)**, proceed as follows:

- A) Unscrew the screws **(1)**.
- B) Remove the guard **(2)**.
- C) Loosen the screw **(3)** and nut **(4)** until the friction wheel **(5)** pressure is released, remove the nut **(7)** and screw **(8)**.
- D) Make sure the friction wheel **(5)** is in contact with the disk **(6)** and replace the screw **(3)** and nut **(4)**, tightening until they press the wheel **(5)** 3 mm against the disk **(6)**.
- E) Screw the screw **(8)** into place and lock the nut **(7)**.
- F) Refit the guard **(2)** and secure it with the screws **(1)**.

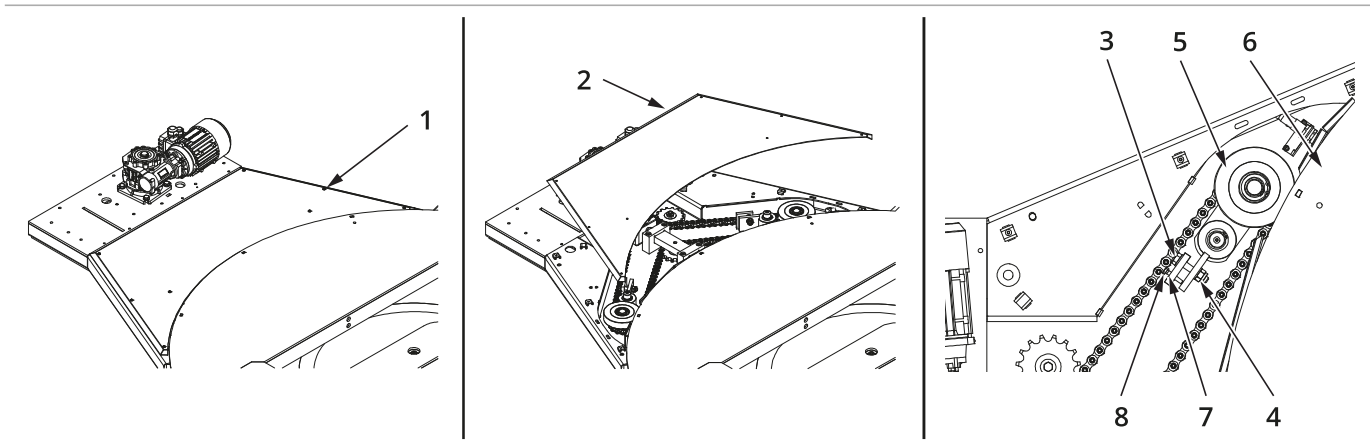

Picture 65

7.2.4 SIX-MONTHLY MAINTENANCE

» See Picture 66 - pag. 91

Check the chains and transmission organs for wear and replace if necessary.

Tensioning the chain

Check the tension of the chain of carriage movement after the first month of use the machine and then every six months.

- A) Remove the screws securing the motor cover **(1)**, and remove the motor cover from place.
- B) Loosen the nut **(2)** blocking the idler pulley. Turn the screw tension **(3)**, placed on the head of the column.
- C) The pulley is then adjusted along the slot, once it reaches the correct chain tension, tighten the lock nut **(2)**.
- D) Replace the motor cover **(1)** and secure with the screws.

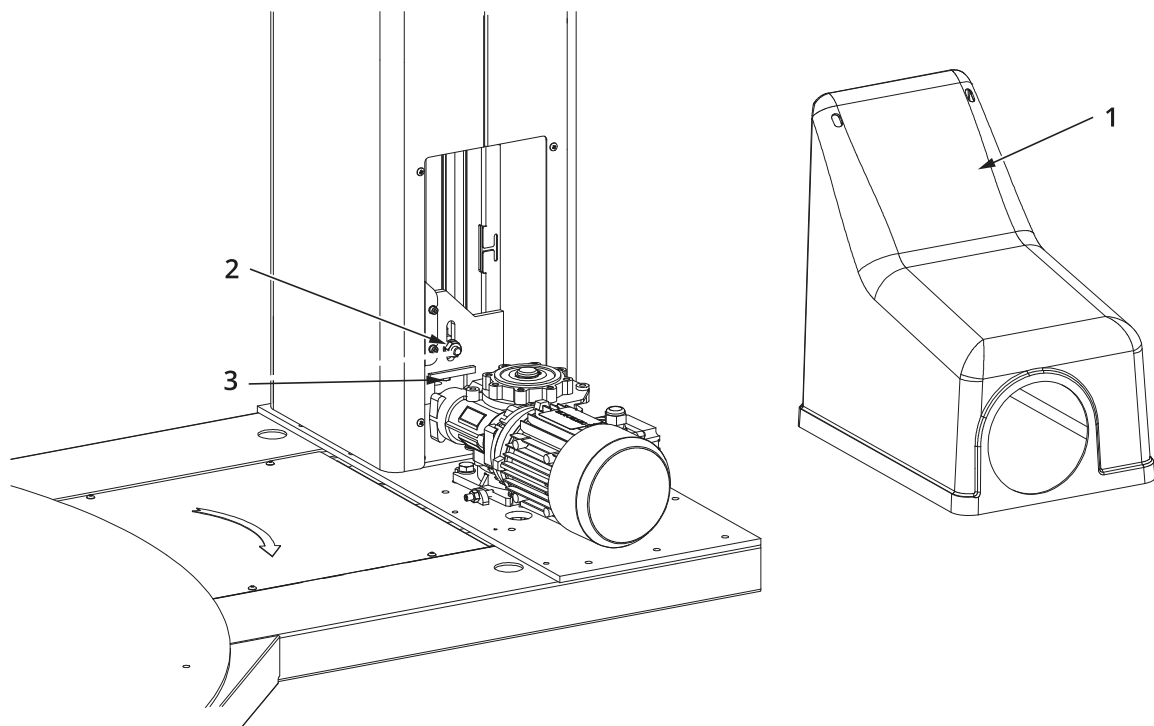

Picture 66

8 OUT OF SERVICE

8.1 DISMANTLING, SCRAPPING AND DISPOSAL

DANGER



IF THE MACHINE OR ITS COMPONENTS ARE FOUND TO BE NO LONGER SERVICEABLE OR REPAIRABLE BECAUSE THEY ARE BROKEN, WORN OR HAVE COME TO THE END OF THEIR WORKING LIFE, THEY MUST BE DEMOLISHED.

- Demolition must be carried out using suitable equipment, chosen on the basis of the type of material in question.
- All components must be dismantled and scrapped after being broken down into smaller parts, so that none of them can reasonably be used again.
- When the machine is scrapped, its parts must be disposed of in a differentiated manner, taking into account their different types (metal, oil and lubricants, plastic, rubber, etc..) handing them over to collection centres authorised for such purposes and in any case conforming to the applicable laws in force governing the disposal of solid industrial waste.

DANGER



NEVER TRY TO RE-USE MACHINE PARTS OR COMPONENTS THAT MAY STILL APPEAR INTACT ONCE THEY HAVE BEEN DECLARED NO LONGER SERVICEABLE.

8.2 DISMANTLING ELECTRONIC PARTS (WEEE DIRECTIVE)



The EU Directive 2012/19/UE (WEEE), requires manufacturers and users of electrical and electronic equipment a number of obligations relating to the collection, treatment, recovery and disposal of such waste.

It is recommended to strictly follow the said rules for disposal of such waste. Illegal dumping of the product by the user entails the administrative sanctions stated by current legislation.



Atlanta Stretch S.p.A.

Via Torrianese, 58

47824 Poggio Torriana (RN) - ITALY

Tel. 0541 627145

www.atlantastretch.com

info@atlantastretch.com