

---

*Rotating table with automatic cycle*

**GENERAL INFORMATION AND MAINTENANCE**  
**Revision 2**



**TRANSLATION OF THE ORIGINAL INSTRUCTIONS**





---

## INDEX

<b>GENERAL INFORMATION</b> .....	<b>5</b>
1.1 AIM OF THE MANUAL .....	5
1.2 CONSERVING THE MANUAL.....	5
1.3 BUILDER.....	5
1.4 CERTIFICATION.....	6
1.5 WARRANTY.....	6
1.6 TECHNICAL ASSISTANCE.....	6
1.7 TASKS TO BE CARRIED OUT BY THE CUSTOMER.....	6
1.8 SYMBOLS AND TERMS .....	6
1.9 MACHINE IDENTIFICATION.....	7
1.10 GENERAL SAFETY INFORMATION.....	8
<b>DESCRIPTION OF THE MACHINE</b> .....	<b>13</b>
2.1 OPERATING PRINCIPLE.....	13
2.2 COMPONENTS OF THE MACHINE.....	13
2.2.1 ACCESSORIES.....	14
2.3 TECHNICAL DATA.....	15
2.4 PLATES AND PICTOGRAMS .....	16
2.5 OVERALL DIMENSIONS OF THE MACHINE .....	18
2.6 NECESSARY SPACE .....	18
2.7 ELECTRICAL TOLERANCES OF THE MACHINE .....	19
2.8 ELECTROMAGNETIC ENVIRONMENT.....	19
2.9 ENVIRONMENTAL CONDITIONS .....	19
2.10 SOUND EMISSIONS.....	19
2.11 VIBRATIONS.....	20
2.12 GAS, DUST AND FUME EMISSIONS .....	20
<b>SAFETY DEVICES</b> .....	<b>21</b>
3.1 EMERGENCY STOP.....	21
3.2 SAFETY DEVICES.....	22
3.3 PROTECTIONS AND FIXED REPAIRS .....	22
3.4 SAFE USE OF THE MACHINE .....	23
3.5 INAPPROPRIATE AND INCORRECT USE.....	24
3.6 OTHER RISKS .....	25
<b>TRANSPORT AND INSTALLATION</b> .....	<b>27</b>
4.1 HANDLING AND TRANSPORT.....	27
4.2 PACKAGING .....	28
4.3 STOCKING.....	29
4.4 INSTALLATION.....	29
4.5 PRELIMINARY INSPECTIONS .....	30
4.6 ELECTRICAL CONNECTION.....	31



---

<b>MAINTENANCE .....</b>	<b>33</b>
5.1 GENERAL INFORMATION ON MAINTANANCE.....	33
5.2 ORDINARY MAINTENANCE.....	34
5.2.1 GREASING.....	34
5.2.2 CHAIN TENSIONING.....	35
5.3 EXTRAORDINARY MAINTENANCE .....	36
5.4 EXTRAORDINARY MAINTENANCE OF ELECTRICAL PARTS.....	36
5.5 CLEANING.....	37
<b>DEMOLITION AND DISPOSAL.....</b>	<b>39</b>
6.1 DISPOSAL OF PRODUCTION WASTE .....	39
6.2 MACHINE DEMOLITION.....	39
DECLARES.....	41

*With a view to continuous improvement of this machine's functions, some of its components and/or characteristics could be modified without notice and without prejudice to the validity of this document. If differences are found between the contents of this manual and the actual machine operation, please communicate them to the Builder.*

## CHAPTER 1

# GENERAL INFORMATION

### 1.1 AIM OF THE MANUAL

This manual is an integral part of the machine and was drawn up by the building company in its own language (Italian) to provide all the necessary information for a correct and safe use throughout its lifecycle (from transport, delivery, installation, use and maintenance to disposal). The manual is divided into sections, chapters and paragraphs, so that the information structure complies with the EU Machinery Directive and with the specific harmonized standards.

Before carrying out any operation on the machine, the operators and skilled technicians must read carefully the instructions included in this manual and must follow them carefully. In case of doubts on the interpretation of the instructions, please turn to the Builder for the necessary explanations. The only way to ensure a correct functioning in the long run and to prevent dangerous situations for people and objects from taking place is to follow these instructions carefully.



**Please carefully read this manual before installing and starting the machine.**

### 1.2 CONSERVING THE MANUAL

The instruction manual should be kept near the machine throughout its lifecycle, should be kept far from any agent that might deteriorate it and should be available for all the operators and skilled technicians that might need it. The manual should be sent with the machine if the machine is sent to a new user or owner.

### 1.3 BUILDER

Wide experience and radical innovation have made the building of this cutting-edge, cost-effective wrapping machine possible. We are always at your disposal to help you with any problem or information request. For any communication or query, please refer to:

***EvoPac srl***  
**Via Calcinaro, 2071**  
**47521 Cesena (FC) - Italy**  
**Tel. 0547.630152**  
**e-mail: [info@evopac.com](mailto:info@evopac.com)**  
**[www.evopac.com](http://www.evopac.com)**

If you need information on use and maintenance, or if you wish to request spare parts, please give the identification data of the machine placed on the Builder plate.



## **1.4 CERTIFICATION**

The machine was manufactured in conformity with the EC Directives in force when the machine was placed on the market, as stated clearly in the declaration of conformity, therefore it complies with the safety requirement of the Machinery Directive *2006/42/CE*.

## **1.5 WARRANTY**

The machine is covered by a warranty on materials for the period indicated in the contractual documents. The buyer loses the right to the warranty if and when modifications or repairs are made to the provision without the manufacturer's consent. Labour and service call charges are not covered by the warranty. In no case can compensation for damages be demanded. For further clarifications on guarantee assistance conditions refer to the sales contract.

## **1.6 TECHNICAL ASSISTANCE**

Ordinary and extraordinary maintenance must be carried out in compliance with the instructions contained in this manual. Should any case occur which is not included here, and for any kind of assistance, please contact directly the Builder, referring to the data written on the plate located on the machine:

- machine model;
- serial number;
- building year e.

Prompt and precise answers can be only guaranteed if the data are referred correctly.

The Builder disclaims any liability for any damage to persons, property or environmental goods, arising from improper use of the machinery, from mistakes in the installation or usage, and due to incompetence, carelessness or neglect with regards to the advice and instructions contained in the manual.

The Builder disclaims any liability for any damage to persons or property, or for any malfunction of the machine, in case of use of non-original spare parts or non-suggested cleaning and maintenance products.

## **1.7 TASKS TO BE CARRIED OUT BY THE CUSTOMER**

The Customer shall carry out the activities indicated in the documents enclosed in the sale contract and within the time agreed with the Builder. If there are not any different agreements the following tasks have to be carried out by the Customer:

- providing the premises and taking care of any brickwork or duct system that might be requested;
- taking care of the sources of energy and of the connection to them, in conformity with the Laws in force in the country in which the machine is used.

## **1.8 SYMBOLS AND TERMS**

The most important parts of the text are in bold and are signalled by the following symbols that are placed before them.



**DANGER:** means that it is necessary to pay attention in order to prevent dangerous situations from taking place and from putting seriously at risk the safety and the health of people or from causing damages to objects.

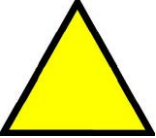

**BEWARE:** highlights critical functions or key information. Pay careful attention to the text highlighted by this symbol.



**INFORMATION:** highlights very important information.





**MAINTENANCE:** refers to information on periodical maintenance that has to be carried out by skilled technicians.

**OPERATOR:** Person who fulfils the necessary requirements and skills and has all the necessary information for the ordinary use of this machine.

**SKILLED TECHNICIAN:** Person who fulfils the necessary requirements to carry out interventions of ordinary maintenance and who has precise information and skills relevant to the specific intervention sector.

## 1.9 MACHINE IDENTIFICATION

The machine is identified by means of the Builder plate located on the machine column. The following data are written on the plate.

	EvoPac S.r.l. Via Calcinaro, 2071 47521 Cesena (FC)- ITALIA Tel. +39.0547.630152 e-mail: info@evopac.com		MACHINE MODEL
TIPO / TYPE			SERIAL NUMBER
MATRICOLA / SR. NUMBER			BUILDING YEAR
ANNO / YEAR			MACHINE MASS (kg)
MASSA / WEIGHT			ABSORBED POWER (kW)
POTENZA / POWER			SUPPLY VOLTAGE (V)
TENSIONE / VOLTAGE			CAPACITY (kg) (MAXIMUM WEIGHT OF LOADING)
PORTATA / CAPACITY			

The machine identification plate, listing the technical data, the serial number and the marking, is visibly located on the electrical panel, as shown in the picture below.



THE IDENTIFICATION PLATE MUST NEVER BE REMOVED.



	EvoPac S.r.l. Via Calcinaro, 2071 47521 Cesena (FC) - ITALIA Tel. +39.0547.630152 e-mail: info@evopac.com	
TIPO / TYPE		
MATRICOLA / SR. NUMBER		
ANNO / YEAR		
MASSA / WEIGHT		
POTENZA / POWER		
TENSIONE / VOLTAGE		
PORTATA / CAPACITY		

### 1.10 GENERAL SAFETY INFORMATION

During project and manufacturing phases, the Builder paid careful attention to all those situations that might cause risks to the safety and the health of people. The relevant laws were fully respected and all the “rules of good building technique” were applied. The aim of this type of information is to raise the awareness of users on the importance of preventing any risk, always using caution.

Carefully read the information reported in the manual and placed directly on the machine, especially safety information.

**Please read this manual carefully before using or servicing the machine.**





- Do not tamper with, sidestep, eliminate or bypass the safety and warning devices installed on the machine. Non-compliance with this requirement can cause serious risks and can compromise the safety of people.
- Never start the machine with the fixed or mobile guards disassembled.
- Never inhibit the emergency features installed on the machine.
- The regulating operations, with reduced safety, must be done by a qualified technician and during their progress it is necessary to prevent access to the machine by unauthorized persons.
- After adjusting the machine under reduced safety conditions, restore proper safety conditions as soon as possible.



- Make sure that the machine is connected to an efficient earthing circuit.
- Do not modify, for any reason, any part of the machine in order to adapt other devices. In case this condition is not respected, the Builder CANNOT be held responsible for malfunction or other related problems. Request any modifications to the Builder's Commercial or Technical Office.

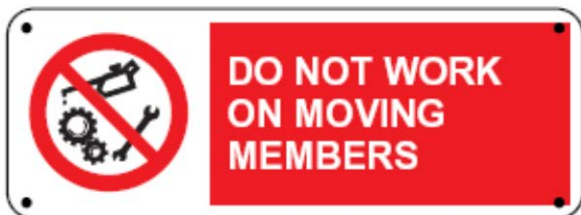

- When in use, some parts of the machine are subject to dangerous voltage. Disconnect power supply and block reinsertion devices before servicing the machine or any equipment connected to it.
- Every intervention on the system or the equipment must be exclusively carried out by qualified electrical maintenance workers.
- Prevent water from dripping onto the electrical panel.

- **Staff persons operating in any way on the machine must have precise technical skills and competences and must have acquired experience in the field. The lack of any of these requirements may compromise the safety and efficiency of the machine.**
- **The operation space that surrounds the machine should be clear of obstacles, cleaned up and very illuminated.**
- **The lighting level should always be such as to guarantee the safest possible working conditions. Should any maintenance operation be necessary in areas or parts of the machine with poor lighting, the maintenance staff must be equipped with a portable lighting system.**



- **Use accident-prevention equipment. Make sure that sleeves are tightened up around the wrists or tucked up. Wear undamaged working clothing and use common sense when operating the machine.**
- **Wear suitable clothing and individual protection devices according to the used products.**
- **Do not use any neckties, bracelets, rings or other things that swinging could be dangerously entangled in parts that are fixed or in motion.**
- **Use the machine in normal psycho-physical conditions.**



- **Should it be necessary to have an assistant or some assistants, train them and inform them on the type of activity to be carried out.**
- **The location of fire extinguishers and their operating instructions must be indicated in the departments.**
- **Make sure that the staff members know how to stop the machine in an emergency.**



- **Do not leave the machine unattended when operating.**
- **Only carry out the actions expressly included in the functional cycle of the machine.**
- **Before starting production, make sure that no people are in the work area.**
- **Tighten all screws, bolts and lock nuts of every adjustable mechanical element following normal tightening values, without using any levers or hitting any spanners.**
- **Never climb onto the machine while operating.**
- **All plates and pictograms must be kept entirely readable. If the identification plate deteriorates with use and turns unreadable, even just partly, a new one should be requested from the Builder, referring to the data contained in this manual or written on the original plate.**
- **Do not clean or lubricate any parts of the machine when operating.**
- **Do not clean the machine with water nor aggressive products, even if diluted.**



# DESCRIPTION OF THE MACHINE

### 2.1 OPERATING PRINCIPLE

This machine is a rotating table wrapping machine to wrap palletized loads with stretch film. By means of an automatic wrapping cycle, it maintains the load's form, dimensions and height while wrapping it.

### 2.2 COMPONENTS OF THE MACHINE

- A. Frame: it is made up of a framework with plates and steel sections in order to provide a strong support to the column and the rotating platform.
- B. Column: it is the part of the machine that supports the film roll carriage, the control panel and the electronic control devices.
- C. Rotating platform: it consists of a circular steel sheet, on which the loads to be wrapped are placed. The rotation takes place by means of a gear motor with chain drive.
- D. Film roll carriage: it holds and winds the stretch film coil.
- E. Control panel: It contains all the buttons for the control and running of the machine. It is located on the column. It is built according to the Directives and to the rules in force.

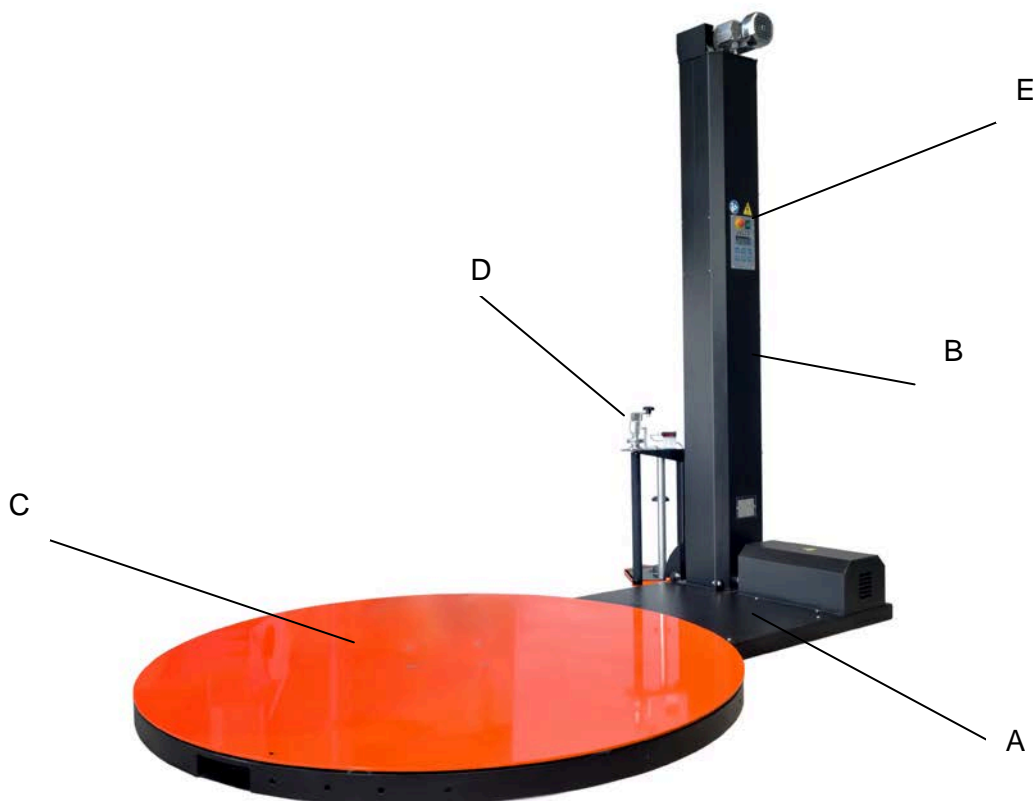

### 2.2.1 ACCESSORIES

A. Power pre-stretch carriage: it allows the film to be pre-stretched before wrapping. It replaces the standard film roll carriage.



The Builder has foreseen and designed a wide range of accessories integrating the machine.

- power pre-stretch carriage;
- ramp to access the table with transpallets;
- clamps to fix the ramp to the ground;
- pit frame;
- photocell for black loads;
- safety cage with door having safety switch;
- clip to tie the film to the turntable.

Accessories, especially if combined, are sufficient to satisfy main needs, improving the machine's performance and simplifying its use.



## 2.3 TECHNICAL DATA

The following are the data and the technical characteristics for a correct installation.

SUPPLY VOLTAGE (V)	230
ABSORBED POWER (kW)	REFER TO DATA ON PLATE
MASS (kg)	REFER TO DATA ON PLATE
DIMENSIONS (mm)	REFER TO PARAGRAPH 2.5
MAXIMUM LOAD WEIGHT (kg)	REFER TO DATA ON PLATE
ROTATION SPEED (RPM)	12
ROTATION WISE	CLOCKWISE

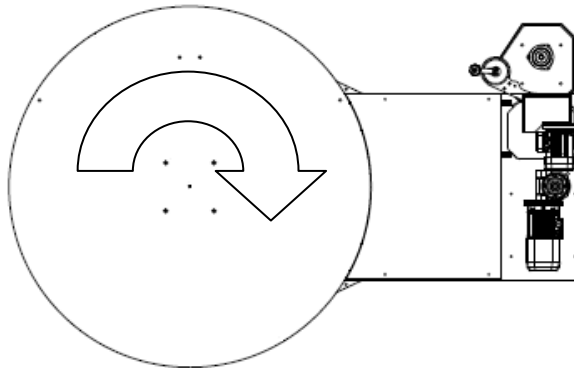

## 2.4 PLATES AND PICTOGRAMS

Please find below a list of the warning pictograms and plates located on the machine.



INDICATES DANGER WARNING OF HAZARDOUS ELECTRICAL VOLTAGE.



INDICATES DANGER WARNING OF BEING TRAPPED OR DRAGGED DUE TO ROTATING PARTS



INDICATES THE REQUIREMENT TO READ THE GENERAL INFORMATION AND MAINTENANCE MANUAL.



INDICATES THE ROTATION DIRECTION OF THE TABLE



**DO NOT REMOVE PLATES OR PICTOGRAMS**

The plates and pictograms must be located on the machine as shown in the pictures.



## 2.5 OVERALL DIMENSIONS OF THE MACHINE

Table D1500

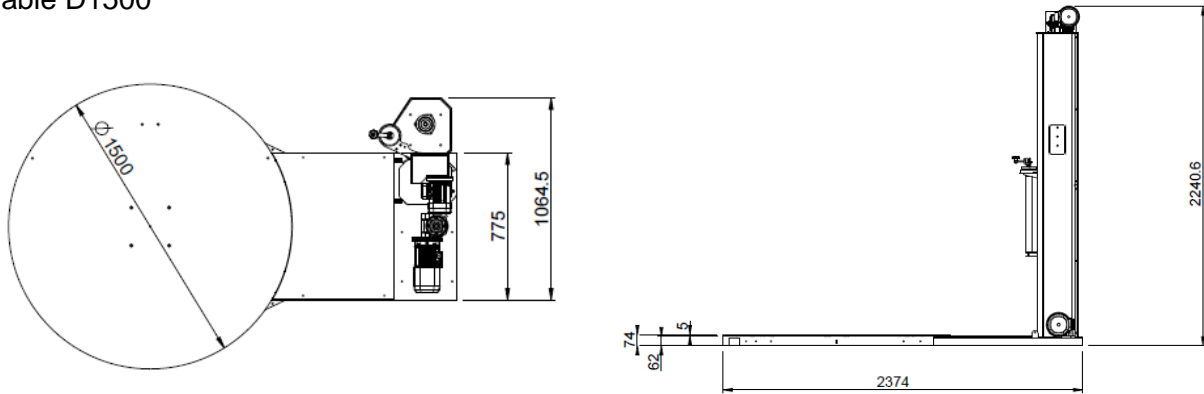
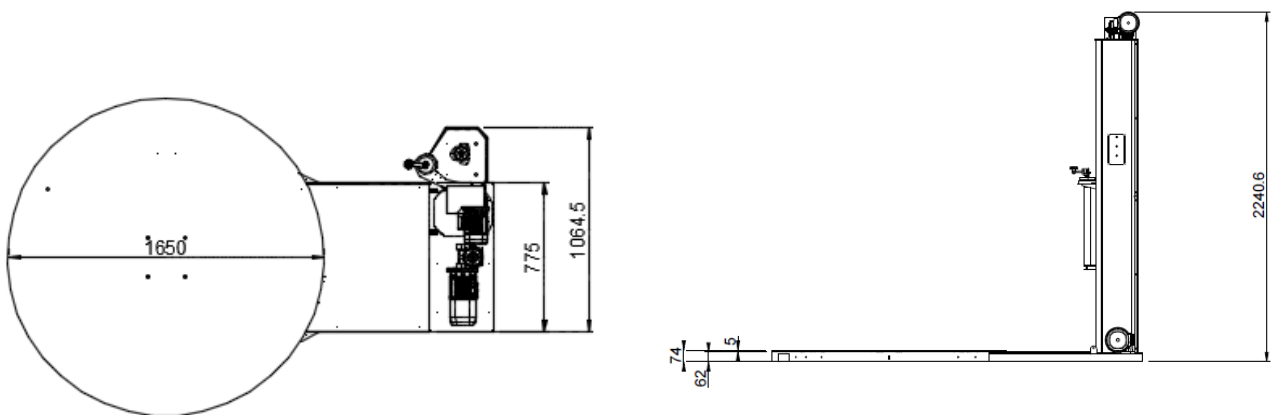

Table D1650



## 2.6 NECESSARY SPACE

The necessary space for using and maintaining the machine can be deduced from the dimensions of the machine itself and from the need to load pallets onto the rotating platform. Under normal usage and maintenance conditions it should therefore be possible to operate comfortably, without any obstacles to accessing the machine, in any of its parts.

## 2.7 ELECTRICAL TOLERANCES OF THE MACHINE



Working voltage: The electrical equipment is designed to operate a nominal voltage of 230V. Any variations will compromise the life of the electrical equipment. If variations larger than the standard values are foreseen, please contact the machine Builder.

## 2.8 ELECTROMAGNETIC ENVIRONMENT

The machine can run in a correct way both in an industrial and in a residential electromagnetic environment. The conformity is guaranteed by the implementation of the Harmonized Technical Norms.

## 2.9 ENVIRONMENTAL CONDITIONS

The machine is designed to operate in indoor environments, with limited exposure to dust and humidity and in an environment with a temperature ranging between 5°C and 40°C.

The machine can work in environments in temperatures less than 5°C or higher than 40°C only if equipped with specific heating or cooling kits.

Environmental conditions different from those prescribed may cause breaking and malfunction. Should environmental conditions be very variable, special measures will have to be agreed with the Builder.

The machine is not designed to operate in explosive atmospheres. **It is therefore forbidden to use the machine in explosive atmospheres.**

The machine has to be installed within a building with a strong and well-levelled flooring. The building lighting has to comply with the laws in force in the country in which the machine is installed and, in any case, it has to ensure adequate visibility on the whole working area that is also used for the handling of products.

## 2.10 SOUND EMISSIONS

After examining the values of  $L_{eq}$  during a test with the machine complete with all its components and placed in an environment without any other sources of noise, the Continuous and Equivalent Level of sound pressure considered in scale "A" [ $L_{eq}$  in dB(A)] at the distance of 1 m when the machine is operating will never be higher than 76 dB(A), as shown in the proof conditions.



The noise values indicated are emission levels and are not necessarily safe operation levels. Although there is a relation between emission and exposure levels, it is not possible to use this relation in a reliable way in order to determine whether other precautions are necessary. The factors which determine the exposure level of the manpower include the duration of the exposure, the features of the working place and other sources of noise (number of machines, contiguous processes, etc.).

Furthermore, the allowed exposure levels can change from country to country.

In any case the information included will help the operator to evaluate any dangers and risks in a more precise way.

## **2.11 VIBRATIONS**

If the machine is used according to the instructions for a correct use, the vibrations cannot cause any dangerous situations.

## **2.12 GAS, DUST AND FUME EMISSIONS**

If the machine is used according to the instructions for a correct use, there are no gas, dust or fume emissions, nor emissions of dangerous substances.

## CHAPTER 3

# SAFETY DEVICES

### 3.1 EMERGENCY STOP

The machine is equipped with a RED disconnecter on yellow background, located on the control panel.



This device only can be reached and operated by the operator during the working cycle, to perform an emergency stop of the machine. By pressing the button, the machine will be safely stopped in the shortest possible time.



To restart the machine after an emergency stop, press the RESET button on the control panel.



**Before restarting the machine after an emergency stop, make sure that the danger has been removed.**

### 3.2 SAFETY DEVICES

The machine is equipped with adequate guards for the protection of the operators exposed to risks due to moving parts and voltage presence. The following protection devices are installed:

- safety limit switch on the film roll carriage. It intervenes when an obstacle prevents the carriage from descending. By intervening it stops the carriage's descent, causes a reverse and makes the carriage slightly go up, to allow obstacle removal.



### 3.3 PROTECTIONS AND FIXED REPAIRS

During designing, a solution has been adopted to prevent / limit the access to dangerous zones of the machine: a series of screw-fixed guards, completely preventing the access to the machine's internal parts.

Due to the fixing systems of the guards, tools are needed to open or remove them.



**Only remove fixed guards during maintenance operations and while the machine is disconnected from the power supply.**



Never remove the pictograms from the guards, and immediately replace them if they are faded or not easily readable.

Never remove fixed guards while the machine is operating.

Never start the machine if any fixed guard is missing. Before starting the machine, make sure that fixed repairs are properly installed.

Never modify or replace fixed repairs with repairs in other materials, or with a different form or function.

The table rotation chain is protected by a walkable plate fixed with screws to the frame.

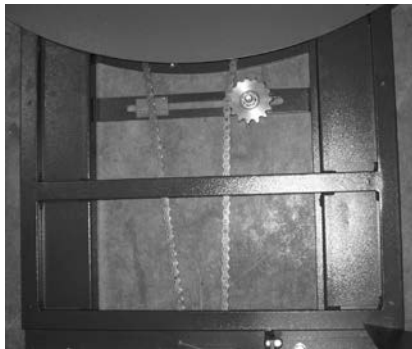

Tighten all screws, bolts and lock nuts of every adjustable mechanical element following normal tightening values, without using any levers or hitting any spanners.  
Do not lose the fixing elements of fixed repairs.

### 3.4 SAFE USE OF THE MACHINE

The machine has been designed and built to wrap exclusively palletized loads with extensible film. The dimensions of the pallets to be wrapped must be adequate to the diameter of the rotating platform.

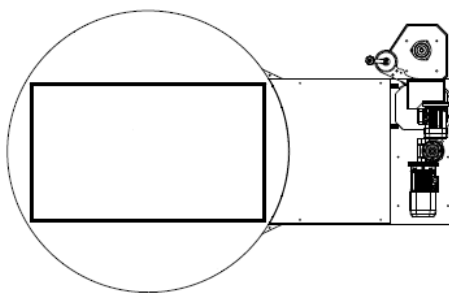

OK

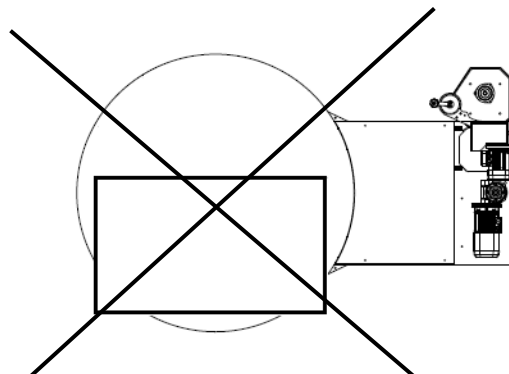

NO



**Do not wrap loads that lean off the table and control that pallets are balanced and centred.**

### **3.5 INAPPROPRIATE AND INCORRECT USE**

This stretchwrapping machine is an automatic machine, designed to wrap palletized loads within the limits set in the descriptions, tables, technical data and documents attached to this manual. Should there be special working needs, please contact the Technical or Commercial Office of the Builder.



Please remember that any changes must be authorized by the Builder in writing.

Any use different from that stated in this manual, not included in, or not deducible from it, must be considered INAPPROPRIATE and FORBIDDEN, because potentially dangerous for the safety of the operators, and it causes the contractual warranty to be invalidated.

#### **It is therefore forbidden to:**

- wrap loads with size or features different from those adequate to the table dimensions;
- use the machine for purposes that differ from the instructions on the correct use;
- use improper or incompatible materials, or auxiliary equipment;
- autonomously change or replace parts of the machine;
- change the speed of the machine components;
- change the machine cycle;
- install non-original parts;
- allow staff not adequately trained to use the machine;
- fail to follow safety instructions;
- fail to follow instructions for installation, use, maintenance and repair;
- fail to follow the safety rules of the workplace or the relative laws and regulations in force.



➤ **DO NOT USE THE MACHINE IN ENVIRONMENTS WITH AN AGGRESSIVE ATMOSPHERE;**



➤ **DO NOT USE THE MACHINE IN ENVIRONMENTS WITH AN EXPLOSIVE ATMOSPHERE.**

### 3.6 OTHER RISKS

Despite all safety devices, the machine involves other risks related to the table rotation and to indispensable carriage movements. Therefore, operators need to:

- pay attention to the warning messages;
- maintain an adequate safety distance from the dangerous parts
- remain at a distance greater than 50 cm from the rotary table while the machine is in operation.

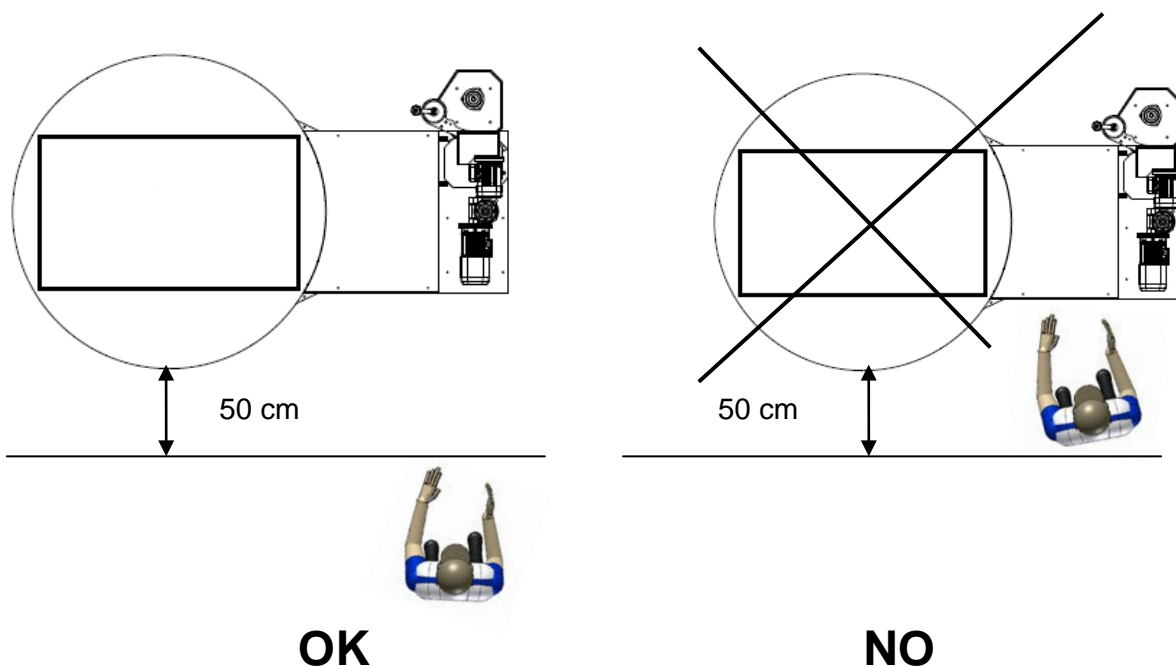

There are no risks of loss of stability, but the machine can be anchored to the floor at the request of the Client. During designing, the Builder can plan where to locate holes for the fixing to the floor.

**Do not intervene on the machine in any way before having consulted the Builder before.**

As for risks of breaking during functioning, it is important to clearly mark off the usage area, to guarantee that the machine elements and the connection parts can bear the stress they have to be subject to during usage, as foreseen by the Builder.

The used materials are sufficiently and adequately resistant for the foreseen usage environment (particularly concerning fatigue, ageing, corrosion and abrasion).

The machine elements and their connection parts have been specifically designed to bear the stress they have to be subject to during usage.

The Builder cannot describe any risks of interference with other machines being used in the workplace of the stretchwrapping machine (e.g. noise, electromagnetic phenomena, etc.), but such risks are not to be excluded.



---

**THE CLIENT IS REQUIRED TO CARRY OUT A RISK ASSESSMENT, CONSIDERING THE MACHINE WORK, THE INSTALLATION PLACE, THE SURROUNDING ENVIRONMENT AND ANY INTERFERENCES WITH OTHER MACHINES.**

# TRANSPORT AND INSTALLATION

### 4.1 HANDLING AND TRANSPORT

The machine can be handled with fork-lift trucks as shown in the pictures below.

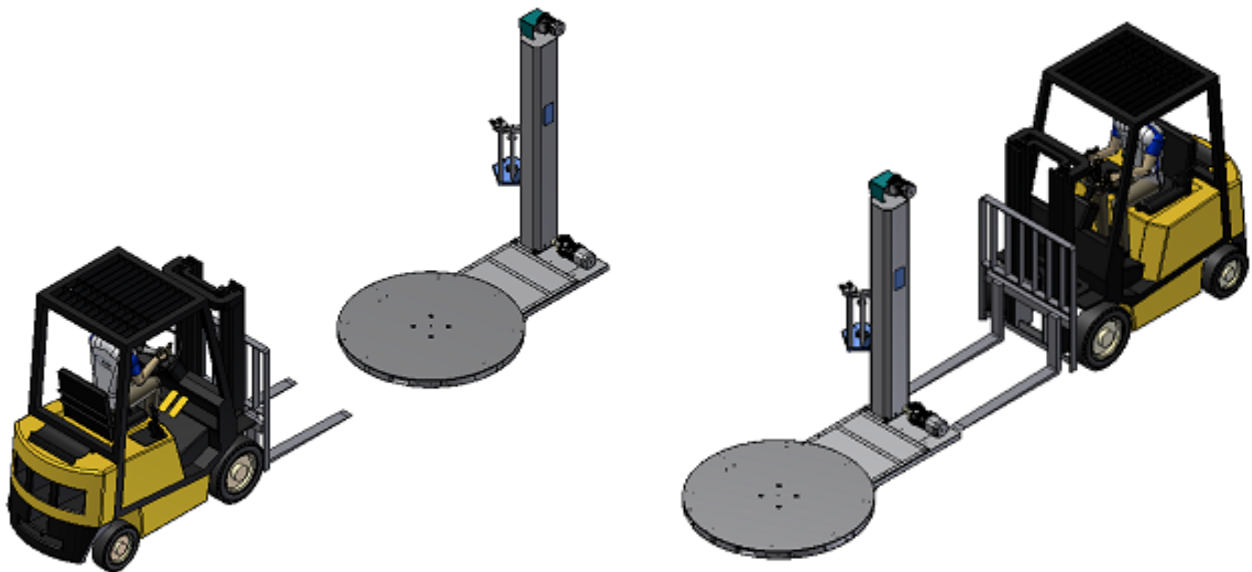

- During handling the machine must be kept as close as possible to the ground.
- Before using the means of transport check their efficiency and their safety systems.
- Check that the carrying capacity of the means of transport is adequate to the machine mass.
- Check that the size of the passage-ways is compatible with the size of the machine.
- Carry the packed machine as near as possible to the installation place.

If made necessary by usage and premises equipment, highlight the layout of forklift traffic routes with pictograms on the plant surface, to ensure workers' safety.



During handling, the machine must always be in a stable and safe position.

While lifting and moving the machine, use maximum caution to avoid dangerous movements, that may cause incidents or damage to persons or property.

Machine handling must always be carried out by experienced staff.

**While lifting and handling the machine, the whole area surrounding it must be considered DANGEROUS ZONE. Therefore, make sure that there are no people exposed to danger in the zone.**



**Non è consentito il trasporto manuale anche per brevi tratti, dovranno sempre essere The machine must not be carried by hand, not even for short stretches. Always use suitable lifting systems and equipments.**



Any damage to the machine that depends on incorrect handling is not included in the warranty. Costs for repairs or for the replacement of damaged parts are to be borne by the Customer.

## 4.2 PACKAGING

Unless differently agreed in the contract, the machine is equipped with the column lying on the rotating platform and protected by packaging material.

Dispose of packaging material in accordance with the laws in force in the country of installation.



The removed packaging materials and all materials collected in the final cleaning phase (wood, metal, plastic, any oily residues, cloths, brackets, cable materials, etc.) must be separately collected according to their type and differently disposed of, in compliance with the environmental protection laws in force.

Should it be necessary to close the machine in a box (e.g. for sea or air transport), the box must have a perimeter base similar to the one of the machine, but 200 mm larger on all sides, with a capacity adequate to the machine weight, and with the appropriate identification pictograms stamped on (together with the indications “THIS SIDE UP” and “HANDLE WITH CARE”).

In the case above or in case of transport on self-propelled vehicles, the machine must be fixed to the box base. The box’s feet must be as high as to allow the passing of lift trucks forks.

### 4.3 STOCKING

In case of a long period of inactivity store the machine:

- in a closed place, protected from severe weather conditions and humidity;
- protecting it from collisions and other types of stress;
- preventing it from coming into contact with corrosive substances.

While the machine is inactive, waiting to be started, it must be located in a dry place, protected from the elements.

### 4.4 INSTALLATION

The machine can be installed by the Builder or directly by the Customer following these instructions.

Remove the package and place the machine on a solid and levelled surface that can support its mass and the mass of the products that will be wound.

To ensure the correct functioning of the machine, the bearing surface must be flat and levelled.

By means of a correct installation the line is more rigid and vibrations and noises are reduced.

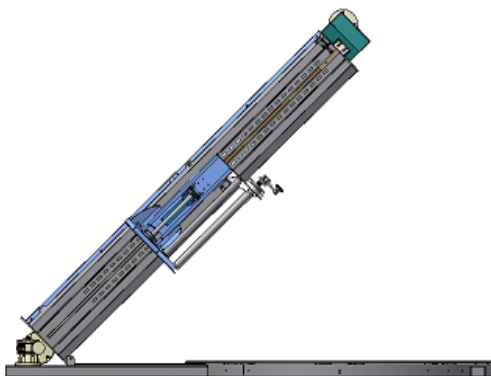

Lift the column as shown in the picture, paying attention not to step on the electric cables. Use suitable lifting equipment.

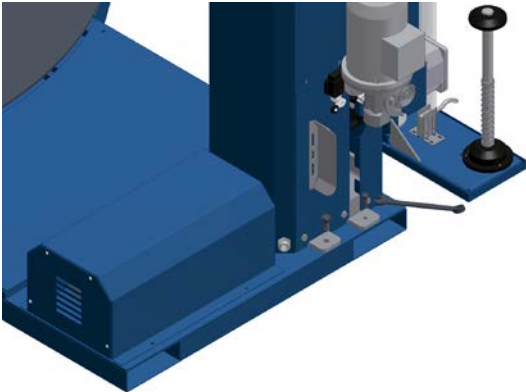

Fix the column to the frame by tightening the screws on the back of the column.

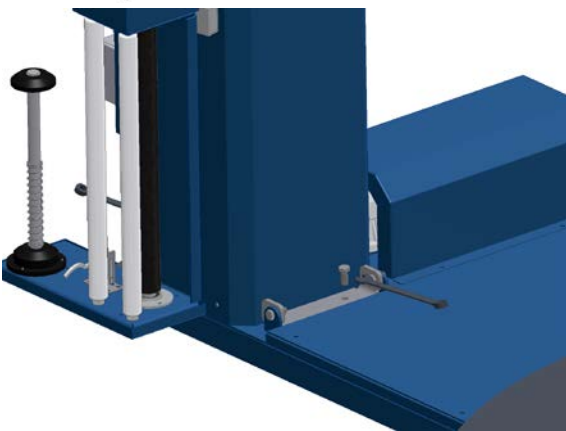

Fix the column to the frame by tightening the screws on the front of the column.



**Tighten all screws, bolts and lock nuts of every adjustable mechanical element following normal tightening values, without using any levers or hitting any spanners.**

**Anchorage operations, if foreseen, must be carried out by authorized and appropriately trained staff.**

#### **4.5 PRELIMINARY INSPECTIONS**

The machine is inspected in the offices of the company of the Builder before being sent, so it is not necessary to follow any particular procedure before it is operated.

The first time the machine is run, follow these instructions:

- check that the machine has not had any damages during transport and handling;
- check that the electric cables are intact;
- check that the machine is correctly connected to the power supply;
- check that all mobile and fixed guards and all safety equipments are correctly installed;
- check that all control sensors are in the correct position.

## 4.6 ELECTRICAL CONNECTION



Before performing the electrical connection, check that a grounding system is present and efficient , and that short circuit and overabsorption protection devices are present.

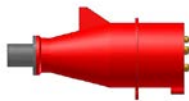

The machine should be connected to the power supply by means of an industrial plug. Electric supply must be provided in conformity with the relevant legislation in the country of use. Supply tension should be the same as specified in the nameplate specifications.

**Electrical connection cables must be protected and so located as not to hamper operators.**



During machine connection to the power grid, the system has to be cut off from the power supply, in compliance with the technical code of practice and the norms in force in the Country of use.

After all preliminary controls have been carried out and the electrical connection has been correctly performed, the machine can be connected to the power supply. Then, check that all machine parts and devices work correctly.



## CHAPTER 5

### MAINTENANCE

#### 5.1 GENERAL INFORMATION ON MAINTANANCE

The procedures recommended in this chapter should be considered the minimum indispensable for proper maintenance of the machine over time operating at its most efficient level. Other procedures may be suggested by user experience taking into account the daily workload, the environment in which the machine is run, the characteristics of the product to be wrapped, etc.

The machine does not require particular maintenance. The technicians assigned to its maintenance shall:

- be properly trained;
- possess sufficient mechanical and electrical knowledge to carry out the work required;
- be aware of health and safety standards;
- be provided with the necessary personal protective equipment and know how to use it properly.



- It is suggested that a sign be placed in a clearly visible position near the machine reading, "MACHINE IN MAINTENANCE".
- It is absolutely forbidden to run the machine in automatic mode with the fixed or mobile guards disassembled.
- Adjustment operations under reduced safety conditions must be carried out by a single operator; during their performance access to the machine by unauthorised staff must be prevented.

- All procedures performed on the plant or on the electrical equipment must be carried out exclusively by a specialised electrician.
- The operating clearance around the machine must be free of obstacles, clean and well lighted.

## 5.2 ORDINARY MAINTENANCE



**Maintenance of mechanical parts must be only carried out by adequately trained operators (mechanical maintainers), while the machine is cut off from the power supply.**

### 5.2.1 GREASING



CARRIAGE GUIDE GREASING



Every three months, or in case of prolonged inactivity, use a brush to spread some lithium grease on the carriage guide

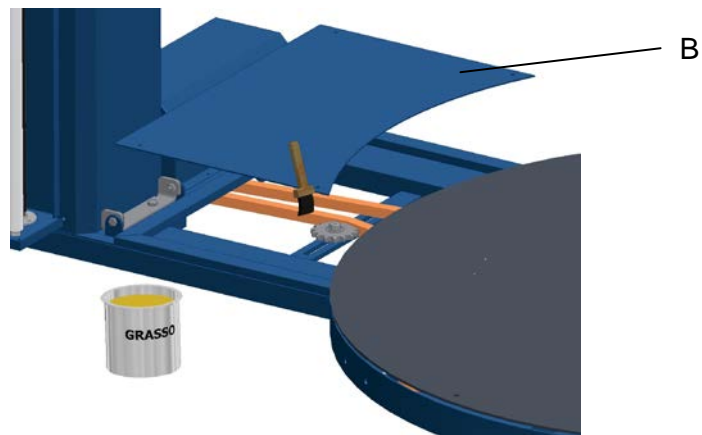

GREASING OF THE TABLE ROTATION CHAIN



Every three months, or in case of prolonged inactivity, use a brush to spread some common cog grease on the rotating platform chain (remove sheet B to access it).

### 5.2.2 CHAIN TENSIONING

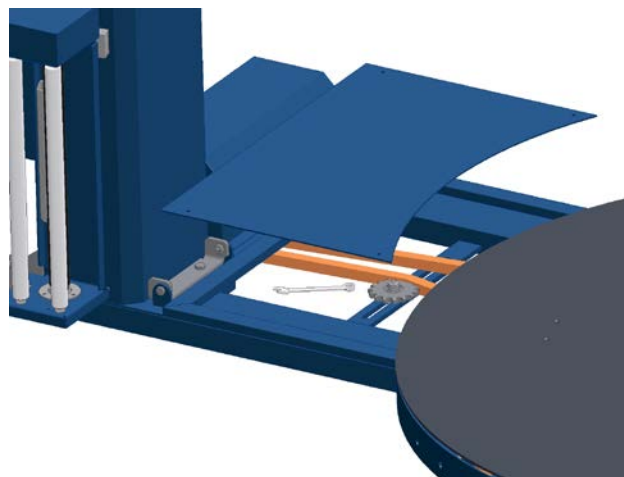

Every three months check the tension of the rotating platform chain by applying a 5-7 kg pressure at their centre and checking that they do not flex more than 1,5 cm towards the inside. If necessary, correct the tension with the chain tensioner.

### 5.3 EXTRAORDINARY MAINTENANCE

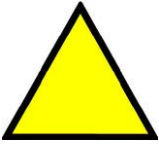

Any maintenance operation different from those described in the previous paragraphs must be considered EXTRAORDINARY MAINTENANCE. Contact with the Builder before carrying out any kind of operation on the machine.

All extraordinary maintenance operations must be carried out by skilled staff, and only after explicit authorisation is obtained from the Builder.



**Inappropriate operations of extraordinary maintenance by staff that was not adequately trained and informed can cause dangerous situations, damage and malfunction.**

### 5.4 EXTRAORDINARY MAINTENANCE OF ELECTRICAL PARTS

Before intervening on the machine's electrical parts:

- get the machine's technical documentation;
- check that the technical documentation corresponds to the machine (the documentation must be up-to-date, as difficulties might arise in working on a machine which has undergone unregistered modifications). **Any modification must be registered and added to the documentation;**



**Disconnect power supply and block reinsertion devices before servicing the machine or any equipment connected to it.**

**During electrical maintenance it is compulsory to:**

- use suitable tools to avoid damage to bolts and tightening screws located on the electrical components;
- should it be necessary to repair the end of cables to be inserted in the terminal boxes or in the fixing holes of electrical devices, use suitable tools and materials with a suitable section, avoiding to damage the insulator;
- register the electrical maintenance procedures carried out and any anomalies found.



---

**IF CHECKS NEED TO BE CARRIED OUT ON ACTIVE PARTS OF THE CIRCUITS WITH VOLTAGE, IT IS COMPULSORY TO:**

- **USE ALL INDIVIDUAL PROTECTION DEVICES COMPLYING WITH THE LAW.**
- **NEVER OPERATE ALONE: A SECOND PERSON MUST ALWAYS BE PRESENT.**

**When the procedures are finished, check that all removed protections have been re-established before restoring power supply.**



About every month or every 200 working hours, while the machine is in operation, check that:

- control devices work properly (warning lights, acoustic signallers and operator panel);
- **safety requirements work properly (emergency button and safety limit switch in the film roll carriage)**

About every month or every 200 working hours, check that the plates indicating the functions of the control and emergency devices are in good conditions.

The identification plates and writings of the control and emergency devices must allow the functions of the devices to be unequivocally identified. Detached or unreadable elements must be adequately fixed in their previous position.



About every month or every 200 working hours, check that the insulation of the machine electrical feeder, and the plugs and sockets at the side of the machine are not damaged.

About every month or every 200 working hours, carry out a visual check of the following limit switches:

- table rotation;
- carriage going up and down.

About every month or every 200 working hours, check that the photocell reading the pallet height is centered and that any support brackets are tightened.

## **5.5 CLEANING**

- Maintain the machine accurately clean, especially in the parts that are in contact with the product and the packaging materials.
- All cleaning operations must be carried out with the machine turned off and disconnected from the power supply.
- Do not allow to unauthorized staff to access the machine.



- **Do not clean the machine with aggressive products, even if diluted.**

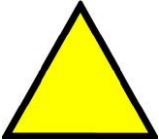

When assessing the hygienic safety of some products (such as food, etc.), it is necessary to make sure that a Quality Plan is correctly implemented in the processing place.

**It is therefore the Client's duty to develop an accurate cleaning plan, according to the product being processed.**

The hygienic state of the machine must be kept under strict control, particularly in specific parts: the packing phase, being at the end of the production cycle, must not compromise the hygiene degree maintained up to that moment.

## **CHAPTER 6**

### **DEMOLITION AND DISPOSAL**

#### **6.1 DISPOSAL OF PRODUCTION WASTE**

If waste material (e.g. waste of plastic film) is generated during processing, it will have to be collected, recycled or disposed of in compliance with the laws in force in the country where the machine is installed.

#### **6.2 MACHINE DEMOLITION**

When dismantling the machine, plastic parts and electrical components must be separated and sent to centres for separate waste collection, according to the laws in force. Metal parts must be divided according to the type of metal for a correct recycling.

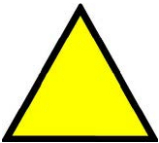

To safeguard the health of people and the safety of objects, demolition operations must be carried out by trained staff with adequate equipment.





---

## **EC- DECLARATION OF CONFORMITY**

under Annex II.A of the 2006/42/EC Directive on Machines

**Evopac S.r.l**  
**Via Calcinaro, 2071**  
**47521 Cesena (FC), Italy**

### ***DECLARES***

Under his sole responsibility that the machine ***TURNTABLE MACHINE WITH AUTOMATIC WORKING CYCLE*** designed for winding pallet loads with extensible film

Model: **NOBEL**

**IS IN CONFORMITY** with the following provisions:

- **European Community Directive 2006/42/EC** – on the safety of machines;

NOTE: the Directive 2006/42/EC replaced the Directive 98/37/EC and its amendments

- **European Community Directive 2014/30/EU and amendments** – on Electromagnetic Compatibility;

NOTE: the Directive 2014/30/EU replaced the Directive 2004/108/EC and its amendments

- **National decrees that implement the Community Directives mentioned above.**

#### **List of the Harmonized Technical Rules applied:**

EN 12100:2010	Safety of machinery -- General principles for design – Risk assessment and risk reduction.
EN 60204-1	Electrical equipment of the machines Part 1: General requirements
EN 61000-6-2	Electromagnetic compatibility (EMC) – Part 6-2: Generic standards – Immunity for industrial environments
EN 61000-6-4	Electromagnetic compatibility (EMC). Generic standards. Emission standard for industrial environments







***EvoPac srl***  
**Via Calcinaro, 2071**  
**47521 Cesena (FC) - Italy**  
**Tel. 0547.630152**  
**e-mail: [info@evopac.com](mailto:info@evopac.com)**  
**[www.evopac.com](http://www.evopac.com)**